

MANUALE D'USO
FORNO D'APPOGGIO COMBINATO A VAPORE

INSTRUCTION MANUAL
COUNTERTOP COMBI STEAM OVEN

MANUEL D'UTILISATION
FOUR À POSER COMBINÉ À VAPEUR

BEDIENUNGSHANDBUCH
KOMBI-STANDBACKOFEN MIT DAMPFGARER

GEBRUIKSAANWIJZING
GECOMBINEERDE STOOMOVEN

MANUAL DE USO
HORNO DE SOBREMESA COMBINADO A VAPOR

MANUAL DE UTILIZAÇÃO
FORNO DE APOIO COMBINADO A VAPOR

IT

EN

FR

DE

NL

ES

PT

Informazioni importanti per l'utente
Important information for the user
Informations importantes pour l'utilisateur
Wichtige Informationen für den Benutzer
Belangrijke informatie voor de gebruiker
Información importante para el usuario
Informações importantes para o utilizador



**Avvertenze / Recommendations / Avertissements / Hinweise /
Waarschuwingen / Advertencias / Advertências**



**Descrizione / Description / Description / Beschreibung / Beschrijving /
Descripción / Descrição**



Uso / Use / Utilisation / Gebrauch / Gebruik / Uso / Utilização



**Pulizia e manutenzione / Cleaning and care / Nettoyage et entretien /
Reinigung und Wartung / Reiniging en onderhoud / Limpieza y mantenimiento /
Limpeza e manutenção**



**Avvertenza di sicurezza / Safety instructions / Consignes de sécurité /
Sicherheitshinweise / Veiligheidswaarschuwingen / Advertencia de seguridad /
Advertências de segurança**



**Informazione / Information / Information / Information / Informatie /
Información / Informação**



**Suggerimento / Advice / Conseil / Empfehlungen / Aanbeveling / Sugerencia /
Sugestões**

Gentile Cliente, La ringraziamo vivamente per il Suo acquisto. I nostri prodotti sono unici perché uniscono una spiccata ricerca estetica alla progettazione tecnica innovativa. Essi sono coordinati con altri prodotti in gamma e possono costituire elementi d'arredo e di design. Augurandole di apprezzare appieno le funzionalità del Suo elettrodomestico, Le porgiamo i nostri più cordiali saluti.

Dear Customer, Thank you for purchasing one of our appliances. Our products are unique because they combine iconic style with innovative technical solutions. They match perfectly with other products in our range and work equally well as a standalone design objects in your kitchen. We hope you enjoy using your new appliance! Best regards.

Cher client, merci beaucoup pour votre achat. Nos produits sont uniques car ils combinent une forte recherche esthétique avec une conception technique innovante. Ils sont coordonnés avec d'autres produits de la gamme et peuvent constituer des éléments d'ameublement et de design. En espérant que vous pourrez apprécier pleinement votre nouvel appareil électroménager, nous vous adressons nos meilleures salutations.

Sehr geehrter Kunde, wir danken Ihnen herzlichst für den Kauf. Unsere Produkte sind einzigartig, da sich in ihnen eine gewissenhafte Designforschung und eine innovative technische Planung vereinen. Sie sind mit anderen Produkten des Sortiments kombinierbar und stellen ausgefallene Einrichtungs- und Designgegenstände dar. Wir hoffen, dass Sie Ihr neues Haushaltsgerät voll und ganz schätzen werden und verbleiben mit freundlichen Grüßen.

Beste klant, hartelijk dank voor uw aankoop. Onze producten zijn uniek omdat ze esthetiek combineren met innovatief technisch ontwerp. De producten zijn uitstekend te combineren andere producten van het assortiment en kunnen worden gebruikt als meubel- en designelementen. We hopen dat u volop van uw nieuwe huishoudelijke apparaat zult genieten. Met vriendelijke groet

Estimado cliente, le damos las gracias por su compra. Nuestros productos son únicos porque combinan una notable búsqueda estética con un diseño técnico innovador. Se combinan con otros productos de la gama y se pueden utilizar como elementos de decoración y diseño. Le deseamos que pueda apreciar plenamente su nuevo electrodoméstico. Le enviamos nuestros saludos más cordiales.

Prezado cliente, Muito obrigado pela sua compra. Os nossos produtos são únicos porque combinam uma forte busca estética com um desenho técnico inovador. São coordenadas com outros produtos da linha e podem constituir elementos de decoração e design. Esperando que possa desfrutar totalmente das funcionalidades do seu eletrodoméstico, enviamos-lhe os nossos melhores cumprimentos.

SMEG S.p.A.

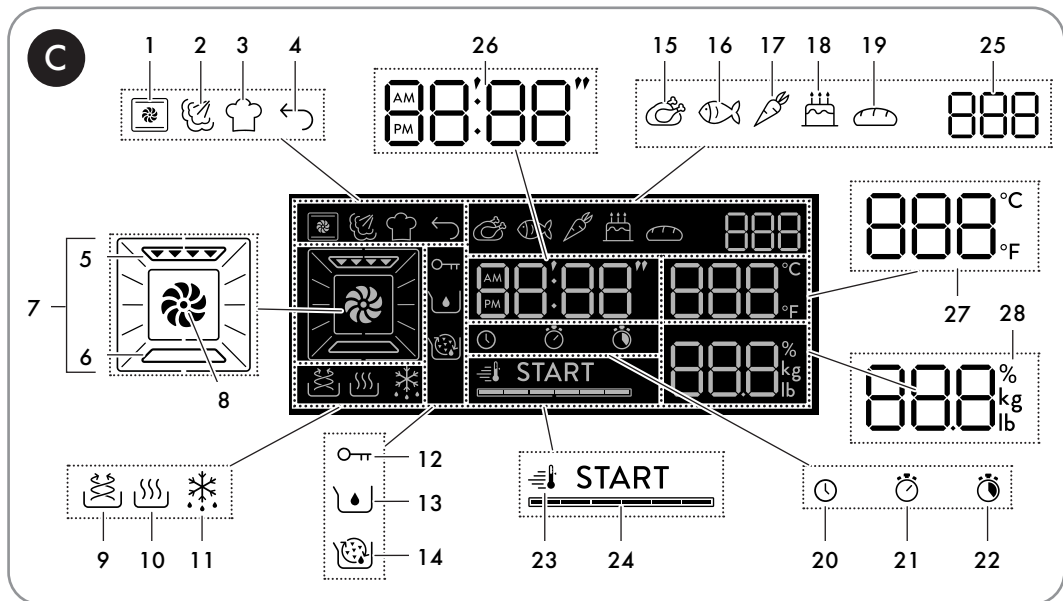
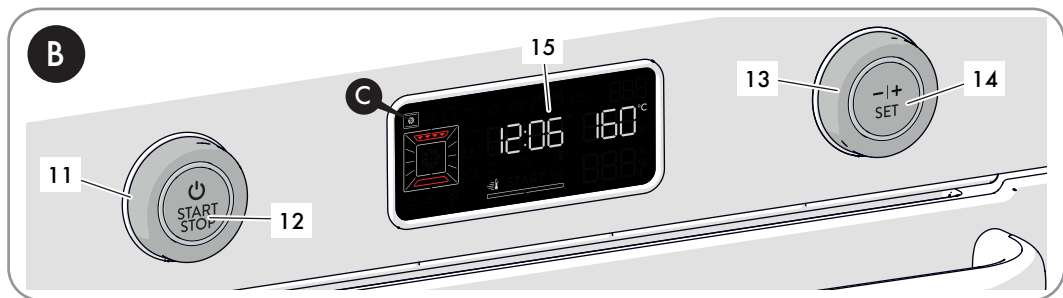
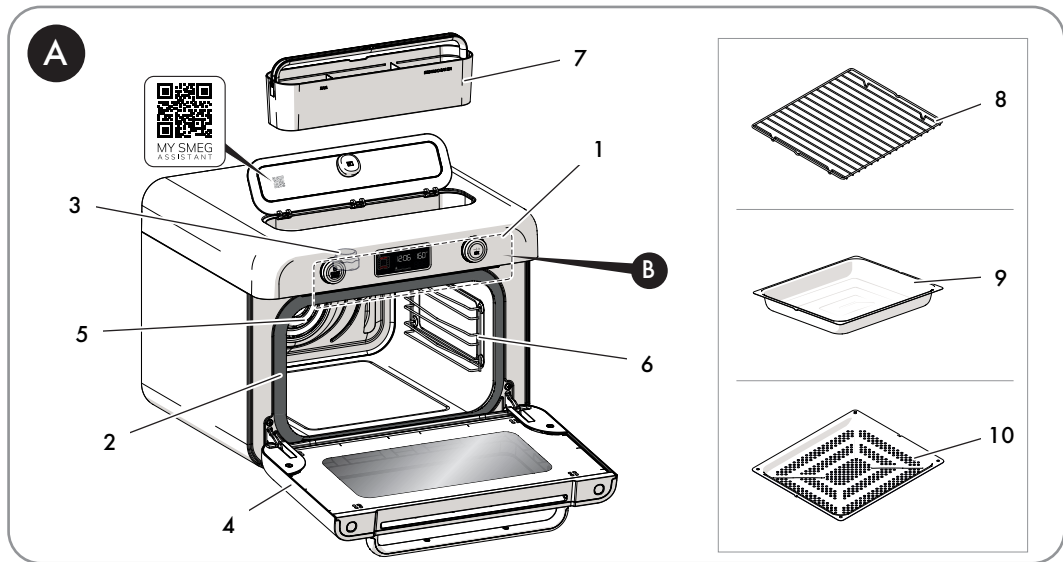

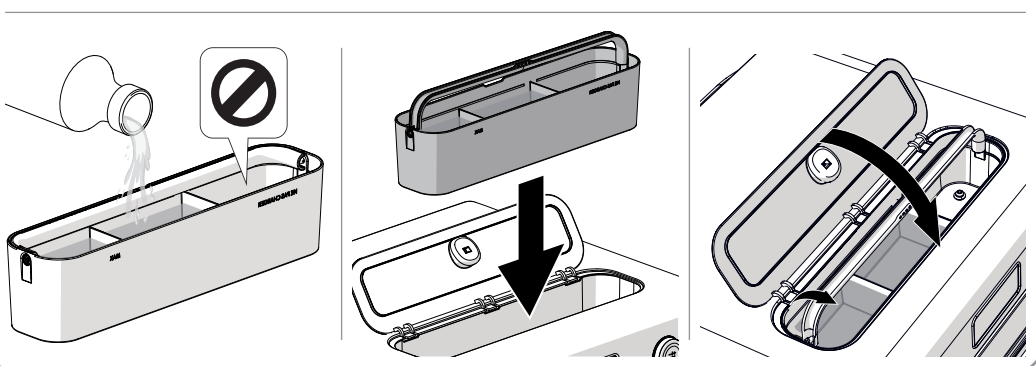
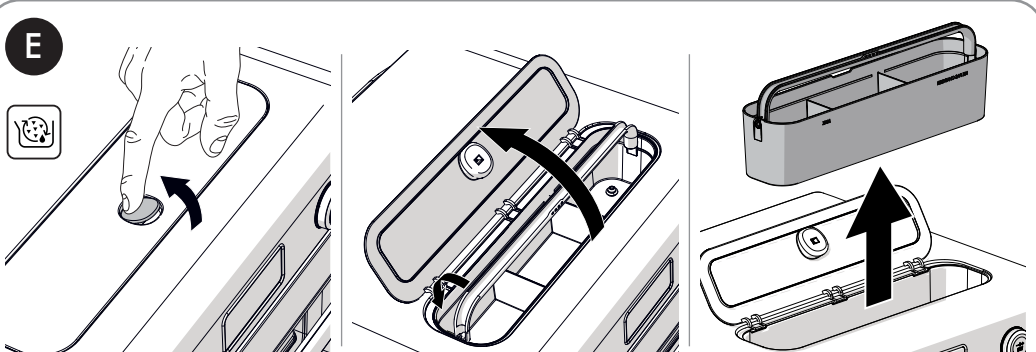
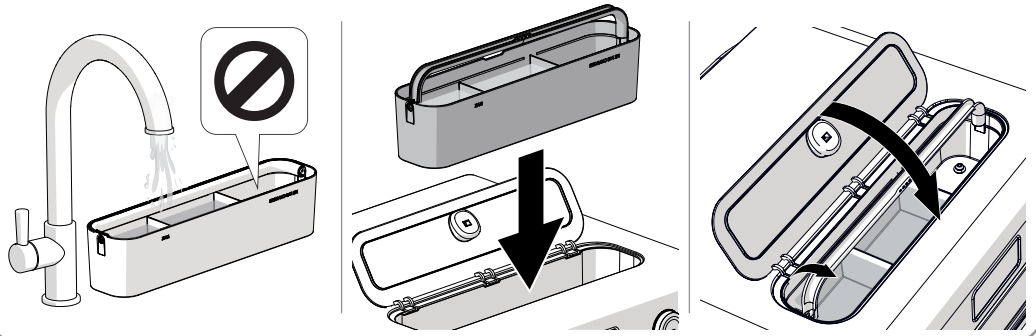
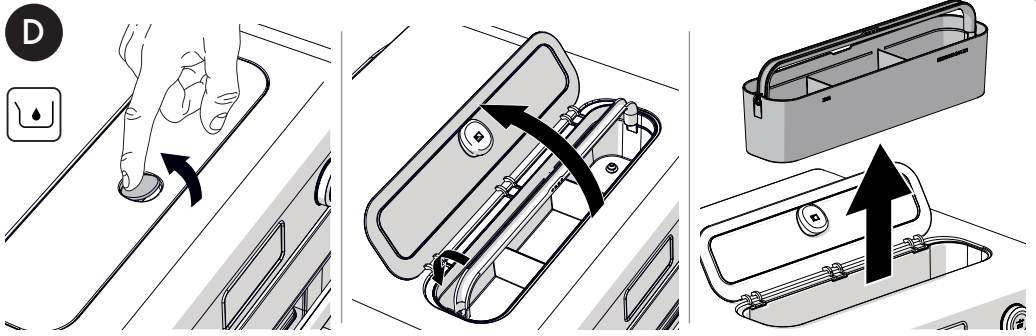



1 Instructions

This user manual is an integral part of the appliance and must therefore be kept in its entirety and within the user's reach for the whole working life of the appliance.

1.1 Intended use

Failure to comply with the safety instructions and failure to read the instructions for the countertop combi oven may lead to the appliance being used incorrectly and cause personal injury.

- Do not use the appliance for purposes other than those for which it was designed. Improper use could cause injury.
- The appliance is not designed to operate with external timers or with remote-control systems.
- Use the appliance indoors, protected from weather conditions.
- This appliance is intended for cooking food in domestic and similar environments, such as:
 - staff kitchen areas in shops, offices and other working environments
 - by guests in hotels, motels and other residential accommodations
 - bed and breakfast facilities / farm accommodation
 - any other use, for example in restaurants, bars and coffee shops is considered improper.

1.2 General safety instructions

Follow all safety instructions in order to use the appliance safely:

- When in use, the appliance and its accessible parts become very hot. Small children should be kept away from the appliance. Never touch the heating elements during use.
- Protect your hands by wearing oven gloves when moving food inside the oven.
- Never try to put out a fire or flames with water: Turn off the appliance and smother the flames with a fire blanket or other appropriate cover.
- This appliance may be used by children aged at least 8 and by people of reduced physical, sensory or mental capacity, or lacking in experience in the use of electrical appliances, provided that they are supervised or instructed by adults who are responsible for their safety.
- Children must not play with the appliance.
- Keep children under the age of 8 away from the appliance and power cable unless they are constantly supervised.



Instructions

- Keep children under the age of 8 away from the appliance when it is in use.
- Cleaning and maintenance must not be carried out by unsupervised children.
- The cooking process must always be monitored. A short cooking process must be continuously monitored.
- Never leave the appliance unattended during cooking operations where fats or oils could be released, as these could then heat up and catch fire.
- Be very careful.
- Do not pour water directly onto very hot trays.
- Keep the oven door closed during cooking.
- If you need to move food or at the end of cooking, open the door 5 cm for a few seconds, let the steam come out, then open it fully.
- The appliance and its parts become very hot during use. Never touch the heating elements during use.
- After use, allow the appliance to cool down. Do not touch the surfaces inside the oven or the heating elements, as they could be very hot. Danger of burns or scalds!
- Do not insert pointed metal objects (cutlery or utensils) into the slots in the appliance.
- Switch off the appliance immediately after use.
- Do not use or store flammable materials near the appliance.
- Do not use aerosols in the vicinity of this appliance whilst it is in use.
- Do not modify this appliance.
- Installation and servicing should be carried out by qualified personnel in accordance with current standards.
- Do not try to repair the appliance yourself or without the assistance of a qualified technician.
- Do not pull the cable to unplug the appliance.



1.3 Caution when using this appliance

- Do not use abrasive or corrosive detergents (e.g. powder products, stain removers and metallic sponges), rough materials or sharp metal scrapers on glass parts as they may scratch the surface and cause the glass to shatter. Use wooden or plastic utensils.
- Do not sit on the appliance.
- Do not use cleaning products containing chlorine, ammonia or bleach on parts made of steel or that have metallic surface finishes (e.g. anodizing, nickel- or chromium-plating).
- Racks and trays should be inserted as far as they will go into the side guides.
- Do not use steam jets to clean the appliance.
- Do not spray any spray products near the appliance.
- Do not obstruct ventilation openings and heat dispersal slots.
- Fire hazard: never leave objects in the oven cavity.
- Do not use the appliance to heat rooms for any reason.
- Do not use plastic cookware or containers when cooking food.
- Do not put sealed tins or containers in the oven.
- Remove all trays and racks which are not required during cooking.
- Do not cover the bottom of the oven cavity with aluminium or tin foil sheets.
- Do not place pans or trays directly on the bottom of the oven cavity.
- If you wish to use greaseproof paper, place it so that it will not interfere with the hot air circulation inside the oven.
- Do not use the open door to rest pans or trays on the internal glass pane.
- Never use the oven door to lever the appliance into place when fitting.
- Avoid exerting too much pressure on the oven door when open.
- Do not use the handle to lift or move the appliance.
- Do not rest any weight or sit on the open door of the appliance.
- Take care that no objects are stuck in the doors.
- Do not install / use the appliance outdoors.
- When cooking with steam functions, be careful not to overfill the tray (800 ml).
- Install / use the appliance on a flat, stable surface.
- In the case of vertical combustible walls, install / use the appliance at a minimum distance of 8 cm.
- This appliance must not be installed in boats or caravans.



Instructions

- The appliance must not be installed on a pedestal.
- Do not immerse the appliance, the power cord or the plug in water or any other liquid.
- Avoid spilling liquids onto the power plug and base.
- If the power cable becomes damaged, contact technical support immediately to arrange for it to be replaced in order to avoid possible hazards.
- Always use any necessary/required personal protective equipment (PPE) before performing any work on the appliance (installation, maintenance, positioning or movement).
- Before performing any work on the appliance, switch off the power supply.
- Allow the appliance to be disconnected after installation, via an accessible plug.
- Before replacing the oven light bulb, make sure that the appliance has been switched off and disconnected from the mains power supply or that the mains power supply has been switched off in order to avoid electric shocks.
- The bulbs used in this appliance are specific for household appliances; do not use them for home lighting.
- This appliance can be used up to a maximum altitude of 4,000 metres above sea level.

1.4 Connecting the appliance

Make sure that the voltage and frequency of the power supply correspond to those indicated on the data plate on the bottom of the appliance.

If the plug of the appliance is not compatible with the socket, contact our Technical Assistance service for a replacement.



Make sure the power cable connector is fully inserted into the connector on the product.

- Children must not play with this appliance.
- Keep the appliance and its power cable out of the reach of children.
- Always unplug the appliance from the power socket if it is to be left unattended and before assembly, disassembly or cleaning.
- Switch off the appliance and disconnect it from the power supply before changing the accessories or approaching moving parts when in use.



1.5 Manufacturer liability

The manufacturer declines any liability for damage to persons or property caused by:

- Use of the appliance other than the one envisaged
- Not having read the user manual
- Tampering with any part of the appliance
- Use of non-original spare parts
- Failure to comply with the safety instructions



Please store these instructions carefully. If the appliance is transferred to others, they should also be given this instructions booklet.

These instructions can be downloaded from the Smeg website “www.smeg.com”.

1.6 Disposal

Electrical appliances must not be disposed of together with household waste.



Devices marked with this symbol are subject to European Directive 2012/19/EU requirements.

- All waste electrical and electronic appliances must be disposed of separately from household waste and taken to authorised waste disposal facilities. Disposing of the used appliance correctly will help to safeguard the environment and human health. For further information regarding the disposal of used appliances, please contact your local authority waste disposal department or the shop where the appliance was purchased.

1.7 To save energy

- Unless otherwise indicated on the package, defrost frozen foods before placing them in the oven.
- When cooking several types of food it is recommended to cook the foods one after the other to make the best use of the already hot oven.
- Use dark metal moulds: they help to absorb the heat better.
- Remove all trays and racks which are not required during cooking.
- Stop cooking a few minutes before the time normally used. Cooking will continue for the remaining minutes with the heat which has accumulated inside the oven.
- Reduce any opening of the door to a minimum to avoid heat dispersal.
- Keep the inside of the oven clean at all times.

1.8 Light sources

- This appliance contains user replaceable light sources.
- The light sources contained in the product are suitable for use in ambient temperatures of $\geq 300^{\circ}\text{C}$ and intended for use in high temperature applications such as ovens.
- This appliance contains efficiency class “G” light sources.



2 Appliance description (Fig. A)

- 1) Control panel and display
- 2) Seal
- 3) Oven light
- 4) Door
- 5) Fan
- 6) Positioning guides
- 7) Removable water reservoir
- 8) Rack
- 9) Enamelled tray
- 10) Perforated tray

2.1 Before first use



Danger of burns

High temperature inside the oven during use.

- Do not remove the earth prong.
- Do not use an adapter.
- Do not use an extension cord.
- Failure to follow these instructions could result in death, fire, or electrical shock.

- Remove any protective film from the outside or inside of the appliance, including accessories.
- Remove any labels (apart from the technical data plate) from the accessories and shelves.
- Remove and wash all the appliance accessories (see chapter "4 Cleaning and maintenance").

- The current time must be set in order to start using the appliance (see "3.2 Using the oven (Fig. B - Fig. C)").



Before use, make sure that all the components are intact.

2.2 Description of the parts (Fig. A)

Water reservoir (7)

Removable water reservoir for steam cooking.

Light (3)

The appliance's interior lighting comes on:

- When the door is opened.
- during cooking.

Internal fan (5)

The fan cools the appliance and comes into operation during cooking.

The fan causes a steady outflow of air from above the door which may continue for a short time even after the appliance has been switched off.

Positioning guides (6)

The appliance has 3 shelves on which to position trays and racks at different heights. The positions are indicated from the bottom upwards.



2.3 Description of accessories (Fig. A)

Rack (8)

Used as a support surface for oven proof containers, moulds or casserole dishes.

Enamelled tray (9)

Tray recommended for traditional cooking of cakes, pizza and baked desserts.

Also useful for collecting fat from foods placed directly on the rack.

Perforated tray (10)

Perforated tray recommended for steam only or combination steam cooking e.g. for fish and vegetables.

Can also be used as an accessory for air-frying already breaded, pre-cooked and/or frozen foods (chips, potato or meat croquettes, bite-size mozzarella etc.).



The accessories intended to come into contact with food are made of materials that comply with the provisions of current legislation.

Cooking containers

- You may also use your own containers for cooking, as long as they are resistant to high temperatures.
- For steam cooking, the use of metal containers is recommended. Metal facilitates better distribution of heat to the foods.
- It is normal for metal containers to deform somewhat during high-temperature cooking, but they will return to their original shape when they cool down.
- Thick ceramic plates may require more heat than normal. Longer cooking times may be necessary.



Description

2.4 Description of the controls (Fig. B)



Menu navigation knob (11)

Allows you to navigate through the various menus and submenus on the user interface. The relative LED has a steady light when you are using the knob.



START/ STOP button (12)

Allows you to confirm the menu and/or the required function (short press) and to start or stop cooking (long press). The relative LED has a steady light when cooking has started and switches off when the cooking cycle has ended.

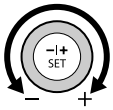

Parameter navigation knob (13)

Allows you to navigate through the various cooking settings that are shown on the display.

The relative LED lights up during configuration.



SET button (14)

Confirms the value that has been set. It displays the settings menu if pressed for at least 3 seconds when the oven is in clock mode. The relative LED lights up when cooking has started and switches off when it has ended.

Display (15)

The display shows the functions, parameters and the values of the cooking settings.

2.5 Description of the display (Fig. C)

Display icons

	Icon	Meaning
1		Traditional Cooking menu
2		Steam Cooking menu
3		Chef Menu
4		Back
5		Grill
6		Bottom fan-assisted cooking
7		Static cooking
8		Fan-assisted cooking
9		Air-Fry
10		Warm
11		Defrost
12		Child lock



	Icon	Meaning
13		Water reservoir empty alarm
14		Descaling alarm
15		Meat and poultry
16		Fish and shellfish
17		Vegetables and side dishes
18		Cakes and sweets
19		Bread, pizza and pies/flans
20		Clock
21		Cooking timer
22		Programmed cooking timer
23		Pre-heating
24		Start + progress bar

Recipe number (25)

Displays the number of the recipe selected from the Chef Menu

Clock and Timer (26)

Displays the time , the cooking time and the programmed cooking timer .

Temperature (27)

Displays the cooking temperature (in °C or °F).

Steam/weight percentage indicator (28)

Displays the percentage (%) of steam used for steam cooking or the weight (in kg or lb) of the food in the Chef Menu function .

3 Use

3.1 First use

- Set a cooking time of at least one hour (see "3.2 Using the oven (Fig. B - Fig. C)").
- Heat the empty oven to the maximum temperature to burn off any residues left by the manufacturing process.
- Ventilate the room and leave the room while the appliance is heating up.
- When the appliance is used for the first time, when heating, it may give off unpleasant smells due to manufacturing residues remaining on some components. These smells usually disappear after the appliance has been heated for the first time.

Using the accessories

Rack and trays have to be inserted into the side guides until they come to a complete stop.



Clean the trays before using them for the first time to remove any residues left by the manufacturing process.



3.2 Using the oven (Fig. B - Fig. C)

Setting the time

When connecting the appliance for the first time or after a power failure, the flashing time **12:00** and the clock symbol  appear on the display. The current time has to be set in order to start a cooking function:

- 1) Turn the right knob to set the hour to the required value.
- 2) Confirm using the SET button.
- 3) Repeat the procedure to set the minutes and confirm the selected time.



To set the current time and/or the display format (12h/24h) see "3.3 Settings Menu".

Selecting the menu and cooking functions

The required menu and, consequently, the cooking function have to be selected in order to start using the oven.



Traditional Cooking menu



Steam Cooking menu



Chef Menu













Go back to the previous menu or level

To select the required menu and function:

- 1) Turn the left knob until you reach the required menu.
- 2) Confirm using the START/STOP button.
- 3) Turn the left knob to navigate through the functions available in the selected menu.
- 4) If you do not wish to modify the cooking settings, start cooking using the START/STOP button.



Menu	Function	Description
TRADITIONAL COOKING		Static Traditional cooking, ideal for preparing a single dish. For example cooking roast meats, fatty meats, bread, pies.
		Fan-assisted Intense and uniform cooking. Ideal for biscuits, cakes and cooking on more than one level.
		Grill Produces excellent grilling and gratinating results. When used at the end of cooking, gives a uniform browning to dishes.
		Bottom fan-assisted The heat comes from the bottom of the cavity. Perfect for cakes, pies, tarts and pizzas.
		Air-Fry Useful for frying without oil or with a small amount of oil. We recommend using the special perforated tray.
		Warm Useful for reheating or keeping food warm.
		Defrost Useful for defrosting frozen foods.
STEAM COOKING		Pure steam cooking Pure steam cooking (100%) ideal for fish, vegetables, chicken, rice, potatoes and desserts. At low temperatures, it can be used to help dough to rise more quickly. We recommend using the special perforated tray.
		Fan + steam Combination fan-assisted and steam cooking (steam level adjustable from 20-70%).
		Fan grill + steam Combination fan-assisted grill and steam cooking (steam level adjustable from 20-70%).

After selecting the cooking function, it will be possible to set the temperature, cooking duration and programmed cooking values, if you wish to do so (see the following pages).







Use

Various recipes can be selected for each food category in the Chef menu.











i The recipes have been designed by Smeg chefs to prepare the most popular dishes in less time. By selecting the type and weight of the dish, the appliance selects the most suitable function, time and temperature.

i Small variations in time are possible according to the ingredients or cooking accessories used, as well as the degree of browning required. We recommend that you always check the food at the end of the preset cooking time.

- 1) Select the menu and the food category.
- 2) Turn the right knob to set the required recipe. The recipe indicator **P** flashes.
- 3) If you do not wish to modify the cooking settings, start cooking using the START/STOP button.
- 4) If you wish to change the recipe once cooking has already started:
 - Press the SET button. The **P** indicator flashes.
 - Turn the right knob to select a new recipe.
 - Confirm using the START/STOP button or wait 5 seconds for automatic confirmation.







Menu	Category	Recipes	Accessory	Shelf indicated from the bottom upwards	
CHEF	 Meat and poultry	P01	Pork spare ribs 	Enamelled tray	1
		P02	Pork sausages	Perforated tray	2
		P03	Roast pork	Enamelled tray	1
		P04	Roast beef	Enamelled tray	1
		P05	Duck stew, in pieces 	Enamelled tray	1
		P06	Whole roast chicken 	Enamelled tray	1
		P07	Chicken nuggets	Perforated tray	1



Menu	Category	Recipes	Accessory	Shelf indicated from the bottom upwards
CHEF	 Fish and shellfish	P08 Salmon fillet/steak	 Perforated tray	2
		P09 Whole fish	 Enamelled tray	1
		P10 Cod au gratin	Perforated tray	1
		P11 Sea bream / sea bass en papillote	Enamelled tray	1
		P12 Calamari/squid/cuttlefish	 Perforated tray	2
		P13 Scallops/mussels au gratin	Perforated tray	2
		P14 Breaded prawns	Perforated tray	2
	 Vegetables and side dishes	P15 Roast potatoes	Enamelled tray	1
		P16 Vegetables au gratin	Enamelled tray	1
		P17 Mixed roasted vegetables	Perforated tray	1
		P18 Stuffed vegetables	 Enamelled tray	1
		P19 Chips/potato croquettes, frozen	Perforated tray	2
	 Cakes and sweets	P20 Chocolate fondant	 Moulds on perforated tray	1
		P21 Apple pie	Cake tin on rack	1
		P22 Tart	Cake tin on rack	1
		P23 Sponge cake	 Cake tin on rack	1
		P24 Cheesecake	Cake tin on rack	1
		P25 Muffin/cupcakes	 Moulds on perforated tray	1
P26 Biscuits		Enamelled tray	1	



Use

Menu	Category	Recipes	Accessory	Shelf indicated from the bottom upwards	
CHEF	 Bread, pizza and pies/flans	P27	Dough proving	 Bowl on the bottom of the oven	1
		P28	Pan baked pizza	Enamelled tray	1
		P29	Lasagne/pasta bake	 Enamelled tray	1
		P30	Potato gnocchi/pot stickers	 Perforated tray	2
		P31	Leavened bread	 Enamelled tray	1
		P32	Focaccia	 Enamelled tray	1
		P33	Vegetable tart	 Cake tin on rack	1

Once the recipe has been selected, it will be possible to modify the weight that has been set (see “Modifying the weight”) and select a programmed start time (see “Setting a programmed cooking cycle”) if you wish to do so. The cooking duration is calculated automatically according to the weight that has been selected, but you can change it if you want to (see “Setting a programmed cooking cycle”).



Modifying the cooking temperature

i Setting not available in the Chef Menu 

Before starting the function:

- 1) Select the menu and the required function.
- 2) Turn the right knob to increase to decrease the temperature (the degrees indicator flashes).
- 3) Press the START/STOP button to start the function.

During cooking:

- 1) Press the SET button.
- 2) Turn the right knob to increase to decrease the temperature (the degrees indicator flashes).
- 3) Confirm using the START/STOP button or wait 5 seconds for cooking to restart automatically with the new values that have been set (the degree indicator stops flashing).

Setting the cooking duration

i Setting not available in the Chef Menu 

- 1) Press the SET button until the timer icon  flashes.
- 2) Turn the right knob to set the cooking duration.
- 3) Confirm using the START/STOP button. If the cooking duration is changed while a function is in progress, follow the instructions above to set the new values and wait 5 seconds for cooking to resume automatically with the new settings.

The remaining cooking time is indicated by the progressive emptying of the progress bar.





Use

Setting a programmed cooking cycle

Programmed cooking allows the cooking to be stopped at a time set by the user. The appliance programs the start of cooking time automatically, according to the duration set by the user and the selected cooking end time.

i The time required for pre-heating is already included in the end-of-cooking time.

- 1) Press the SET button until the flashing programmed cooking icon  is displayed.
- 2) Turn the right knob to set the cooking end time.
- 3) Confirm using the START/STOP button. The appliance waits for the set start time.



- It is not possible to set the cooking end time without having set the cooking duration.
- It is not possible to set a programmed cooking cycle if cooking has already started.

To cancel a programmed cooking cycle:

- 1) Press the SET button until the flashing programmed cooking icon  is displayed.
- 2) Turn the right knob anticlockwise until you reach the current time and reset programmed cooking.
- 3) Confirm using the START/STOP button.

Changing the level of steam

i Setting available only in the Steam Cooking menu 

In the combination cooking functions (fan-assisted and grill) the steam level can be adjusted from a minimum of 20% to a maximum of 70%:

- 1) Press the SET button until the % indicator appears and flashes.
- 2) Turn the right knob to increase or decrease the steam level required.
- 3) Confirm using the START/STOP button. If the steam level is changed while a function is in progress, follow the instructions above to set the new values and wait 5 seconds for cooking to resume automatically with the new settings.

Modifying the weight

i Setting available only in the Chef menu 

- 1) Press the SET button until the unit of measurement (kg/lb) appears and flashes.
- 2) Turn the right knob to modify the weight that has been set (the cooking duration will be updated automatically).
- 3) Confirm using the START/STOP button. If the weight is changed while a function is in progress, follow the instructions above to set the new values and wait 5 seconds for cooking to resume automatically with the new settings.



Preheating stage

Cooking is always preceded by a preheating stage , which allows the appliance to heat to the cooking temperature more quickly.

During this stage, the indicator  lights up and the progressive temperature level that has been reached is shown.



Unless otherwise indicated in the recipe, it is not recommended to place food in the oven during the preheating stage.

When the preheating stage has finished, a buzzer will sound to indicate that the cooking phase is starting. This must be confirmed by pressing the START/STOP button or by placing the dish in the oven.



If a cooking timer has been set, the countdown will start automatically once confirmed at the end of the preheating phase.

Starting cooking

- 1) Open the door.
- 2) Place the food to be cooked in the oven.
- 3) Close the door. Cooking starts automatically and the  indicator switches off.



If the dish has already been placed in the oven, the START/STOP button (13) has to be pressed in order for cooking to start, also after the preheating stage has finished.

End of cooking

If a cooking duration has been set, it ends automatically. The text **End**, appears on the display, the timer icon  flashes and a buzzer sounds, which can be deactivated using the START/STOP button.

To end cooking manually and go back to the clock display, press and hold the START/STOP button for at least 3 seconds.

Residual heat

After you have finished using the appliance, if the oven is still hot, the residual heat indicator will appear on the display.



The indicated heat level decreases automatically as the temperature decreases, until it switches off.

Filling the reservoir for steam cooking (Fig. D)



If there is no water in the reservoir, it is indicated by the flashing  light.

- 1) Press the release button on top of the lid and pull to open.
- 2) Lift the handle and remove the reservoir.
- 3) Fill the left filling compartment with water up to the MAX level indicated on the reservoir.



Use



Use cold tap water which is not too hard, softened water or still mineral water.



Do not use distilled water, tap water with a high chloride content (> 40 mg/l), or other liquids.

- 4) Place the reservoir in the oven compartment and close the lid.
- 5) When finished, confirm using the START/STOP button.



Caution

Do not fill the compartment on the right, which is used exclusively for draining water (or other liquids) in the reservoir.



If the water reservoir is empty during steam cooking, the cooking process stops and remains in standby for a maximum of 5 minutes. Cooking resumes once confirmation has been received that the reservoir has been filled. If, at the end of the maximum standby time of 5 minutes, the water reservoir has not been filled, the appliance continues cooking without steam or, in the case of the pure steam function, it finishes cooking.

3.3 Settings Menu



The settings menu can only be accessed when the oven is in clock mode.

- 1) Press the SET button for at least 3 seconds.
- 2) Turn the left knob to navigate through the items in the menu.
- 3) Turn the right knob to set the required value and confirm using the SET button.
- 4) Press the SET button for at least 3 seconds to save the configuration and exit from the menu.

Loc Child lock

This function allows the appliance to lock (On) the controls.

When the function is active, the indicator  lights up on the display.



To disable the function, go back to the Settings menu and select OFF.

Std Sound

Enables (On) or disables (OFF) the sounds emitted by the oven.

CLoF Clock format

Sets the time display to a 12 (12H) or 24 hour (24H) format.



The factory default time Format function is set to 24h.



Modifying the time

- 1) The clock icon  appears on the display and the hours start to flash.
- 2) Turn the right knob to the required value.
- 3) Confirm using the SET button.
- 4) Repeat the procedure to set the minutes.



The set time can always be changed by accessing the settings menu and turning the left-hand knob until the time appears flashing on the display.

unit Setting the units of measurement

Set the units of measurement for temperature and weight (for the Chef Menu) according to the following table:

Hardness level	Temperature	Weight
EU	°C	kg
US	°F	lb

brl Display brightness

This allows you to select the brightness of the display according to the following table:

Hardness level	Display brightness
1	25%
2	35%
3	50%
4	70%
5	90%



The factory default Display brightness function is set to 5.

ELCD Display ECO function

If enabled (On), it allows the brightness of the display to be lowered automatically when the oven is in clock mode.



It has no effect if the brightness of the display is already set to 1.

hArD Water hardness

Allows you to set the level of water hardness in order to optimise the descaling process.



The factory default water Hardness function is set to medium 3.

The frequency with which you are promoted to run a descaling cycle depends on the water hardness setting.

The number of hours of use of the steam functions, at the end of which descaling will be requested, is as follows:

Hardness level	Hours
1	18
2	12
3	9
4	6
5	4

DESC Descaling

If enabled (On) it allows you to start a descaling cycle (see "4.1 Descaling (Fig. E)").



4 Cleaning and maintenance

The instructions manual contains cleaning and maintenance instructions and recommendations from the manufacturer to the customer. Any other intervention should be carried out by an authorised service centre.

Before cleaning, ALWAYS remove the plug from the mains power supply and allow the appliance to cool down.



Caution

- Do not use steam jets to clean the appliance.
- Do not use cleaning products containing chlorine, ammonia or bleach on steel parts or parts with metallic surface finishes.
- Do not use abrasive or corrosive detergents.
- Do not use rough or abrasive materials or sharp metal scrapers.
- Clean the components and accessories regularly after each use.

Cleaning the surfaces

To keep the surfaces in good condition, they should be cleaned regularly after use. Let them cool first.

Ordinary daily cleaning

Always and only use specific products that do not contain abrasives or chlorine-based acids.

Pour the product onto a damp cloth and wipe the surface, rinse thoroughly and dry with a soft cloth or a microfibre cloth.

Food stains or residues

Do not use steel sponges and sharp scrapers as they will damage the surface.

Use normal, non-abrasive products and a wooden or plastic tool, if necessary. Rinse thoroughly and dry with a soft cloth or a microfibre cloth.

Do not allow residues of sugary foods (such as jam) to set inside the oven. If left to set for too long, they might damage the enamel lining of the oven.



Cleaning the accessories

Wash all accessories in warm soapy water with a soft sponge or a soft cloth. Rinse and dry thoroughly. Do not use abrasive detergents, metallic sponges or metal tools to clean the accessories as they may damage the surfaces.

In order to extend the life of the accessories, it is recommended not to wash them in a dishwasher.

Cleaning the door glazing

The glass in the door should always be kept perfectly clean. Use absorbent kitchen roll. In case of stubborn dirt, wash with a damp sponge and an ordinary detergent.

Cleaning the oven cavity

In order to keep your oven in the best possible condition, clean it regularly after letting it cool down.

Avoid letting food residue dry inside the oven cavity, as this could damage the enamel.

For easier cleaning, we recommend that you remove the side guides.

Simply pull the frame, carefully, to release it from the fastenings at the side. To reinstall it, just insert it into the side fastenings and apply light pressure.

Using the steam function for assisted cleaning

The steam function can be used to soften any cooking residues, making it easier to remove them.

Before starting the function, we recommend that you spray a solution of water and washing up liquid onto the side walls of the cooking compartment.

- 1) Select the pure Steam function from the Steam cooking menu.
- 2) Set the temperature to 100°C for 18 minutes.
- 3) Press the START/STOP button to start the function; when the preheating stage has finished, press the START/STOP button again.
- 4) When a function ends, open the door and use a microfibre cloth to finish cleaning the inside of the oven.

Drying

Cooking food generates moisture inside the appliance. This is a normal phenomenon and does not affect the appliance's operation in any way.

Each time you finish cooking:

- 1) Let the appliance cool down.
- 2) Remove any dirt from inside the appliance.
- 3) Dry the inside of the appliance with a soft cloth.
- 4) Leave the door open until the inside of the appliance has dried completely.



Cleaning and maintenance

4.1 Descaling (Fig. E)

Whenever the  icon appears steadily lit on the display, it is highly recommended that you descale the boiler.

Whenever the flashing  icon appears on the display, it means that the boiler has to be descaled and that it is not possible to select cooking cycles that use steam until this step has been completed.



The frequency with which descaling is requested varies according to the water hardness that has been set (see "3.3 Settings Menu").



If considered appropriate, it is always possible to run the descaling cycle in advance.



Caution
Scale build-up due to lack of descaling can compromise the correct operation of the appliance in the long term.

1) To access the descaling function, enter the settings Menu (see "3.3 Settings Menu").

2) Turn the left knob until the display shows

DESC

3) Turn the right knob to enable the function (On) and confirm using the SET button to start the descaling cycle.

4) To cancel the descaling cycle, press the START/STOP button for at least 3 seconds.



Caution

Once the descaling cycle has been started, it can only be stopped before the container filling cycle with descaler solution ends (see following paragraph St2). Afterwards, the appliance will not allow you to run any other function until the descaling process has finished. The entire duration of the cycle is approximately 40 minutes.



The user should remain next to the appliance for the entire duration of the descaling cycle, as user interventions may be required, such as topping-up the reservoir.



The cycle consists of 6 steps, indicated by the progressive emptying of the progress bar (24) and by the indicators on the display St1, St2,



Draining residual water (St1)

- 1) The appliance removes the residual water by draining it into the compartment on the right.
- 2) Press the release button on top of the lid and pull to open.
- 3) Lift the handle, remove the reservoir and empty it.



Caution
The water may be very hot.

Filling the reservoir with descaler solution (St2)

- 1) Fill the filling compartment on the left with a solution of water and descaler according to the manufacturer's recommendations.



Caution
Do not fill the water drainage compartment on the right.



Use cold tap water which is not too hard, softened water or still mineral water.



Do not use distilled water, tap water with a high chloride content (> 40 mg/l), or other liquids.

- 2) Place the reservoir in the oven compartment and close the lid.



It is now no longer possible to cancel the descaling cycle.

Starting the descaling function (St3)

- 1) Press the SET button to confirm.
- 2) The appliance starts the boiler cleaning procedure and the display shows the entire duration of the procedure.



During the descaling process, the appliance will pause a few times to allow the descaler to act effectively. Wait for the cycle to end.

Draining the descaler solution (St4)

- 1) At the end of the cleaning process, the appliance drains the remaining descaler solution into the drainage compartment of the reservoir.
- 2) Remove the reservoir and empty the descaler solution.



Caution
The descaler solution may still be very hot.



Cleaning and maintenance

Filling the reservoir with clean water (St5)

- 1) Clean the reservoir and fill the left filling compartment with clean water up to the MAX level.
- 2) Place the reservoir in the oven compartment and close the lid.
- 3) Press the SET button to confirm.

Rinsing the water circuit (St6)

- 1) The appliance starts the water circuit cleaning procedure and the display shows the entire duration of the procedure.
- 2) At the end of the rinse cycle, **End** is shown on the display and a buzzer sounds.
- 3) Press the START/STOP button for at least 3 seconds to exit from the descaling function.

Seal maintenance

The seal should be soft and elastic.

To keep the seal clean, use a non-abrasive sponge and wash with lukewarm water.

Replacing the internal light bulb



Caution

- Unplug the appliance.
- Use protective gloves.
- Let the appliance cool down.

- 1) Completely remove all accessories from inside the oven.
- 2) Unscrew the bulb cover by hand and remove it.



Pay attention not to scratch the oven cavity enamel.

- 3) Slide out and remove the light bulb.
- 4) Reinstall the protective cover after replacing the bulb.



What to do if...

Problem	Possible cause	Solution
The oven does not switch on.	The plug has not been properly inserted into the power socket.	Make sure the plug has been inserted properly into the power socket.
	The cable is defective.	Contact your local technical support centre.
	No power.	Make sure that the power supply is working properly. If the problem persists, contact a qualified electrician.
The display does not turn on.	The plug has not been properly inserted into the power socket.	Make sure the plug has been inserted properly into the power socket.
	Possible electronic board failure.	Contact your local technical support centre.
The oven light does not switch on.	The plug has not been properly inserted into the power socket.	Make sure the plug has been inserted properly into the power socket.
	Possible bulb or oven door sensor failure.	Replace the oven light bulb (see "4 Cleaning and maintenance"). If the problem persists, contact your local technical support centre.
Cooking does not start.	Failure to confirm after preheating (☰ lit).	Make sure that you confirm the cooking phase when the preheating stage ends (see "3.2 Using the oven (Fig. B - Fig. C)").
	The oven door is not closed.	Make sure that the oven door is closed.
	Possible oven door sensor failure.	Contact your local technical support centre.

What to do if...

Problem	Possible cause	Solution
Cooking has started but the oven does not heat up.	The oven door is not closed.	Make sure that the oven door is closed.
	Possible heating elements or oven door sensor failure.	Contact your local technical support centre.
The sound of a fan can be heard even after the power has been turned off.	The fan continues to run to cool the appliance until the internal temperature is low enough.	Wait for the time necessary for the appliance to cool down. If the fan does not switch off after this time, contact your local technical support centre.
	It is normal for hot air to escape from above the door to cool the appliance whilst it is in operation.	Wait for the appliance to cool down normally. If the hot air continues to escape or if it escapes from other parts of the oven, contact your local technical support centre.
There is a burning smell when the oven is in operation.	There may be a burning smell when using the appliance for the first time.	Make sure you have followed the instructions when using the appliance for the first time (see "3.1 First use").
	Possible food residues inside the appliance in contact with the heating elements.	Make sure you follow the cleaning and maintenance instructions correctly (see "4 Cleaning and maintenance").

What to do if...

Problem	Possible cause	Solution
The oven does not generate steam.	The water reservoir has not been inserted correctly in the oven compartment.	Make sure that the water reservoir has been inserted correctly in the oven compartment.
	The water reservoir is empty or not full enough (flashing  alarm).	Fill the reservoir with water up to the MAX level indicated on the reservoir.
	The filling compartment of the water reservoir has not been filled.	Make sure that the left filling compartment of the reservoir has been filled with water.
	Mandatory descaling required (flashing  alarm).	Run a descaling cycle (see "4.1 Descaling (Fig. E)").
When in use, steam escapes from above the oven door.	Possible boiler failure.	Contact your local technical support centre.
	It is normal for steam to escape from above the door to cool the appliance whilst it is in operation and to control the steam cooking cycle.	Wait for the appliance to cool down normally. If steam continues to escape or if it escapes from other parts of the oven, contact your local technical support centre.

What to do if...

Problem	Possible cause	Solution
Water drips onto the shelf from under the door during operation.	During operation, food with a high moisture content (such as frozen bread) may create condensation that slides down the inside of the door and drips onto the shelf.	If excessive water leaks persist, contact your local technical support centre.
	The oven door is opened frequently while the oven is in use.	Reduce the number of times the oven door is opened or closed during cooking.
	Possible problem with the seal.	Contact your local technical support centre.
The water reservoir does not fit into the oven compartment.	The water reservoir has not been inserted the correct way round.	Make sure that the water reservoir is inserted the correct way round and that the door is closed.
One of the following error codes appears on the display: Err1 / Err2 / Err3 / Err4 / Err 5	Possible internal fault.	Contact your local technical support centre.



If the problem has not been resolved or in the case of other types of fault, contact your local technical support centre.

Il costruttore si riserva di apportare senza preavviso tutte le modifiche che riterrà utili al miglioramento dei propri prodotti. Le illustrazioni e le descrizioni contenute in questo manuale non sono quindi impegnative ed hanno solo valore indicativo.

The manufacturer reserves the right to make any changes deemed necessary for the improvement of its products without prior notice. The illustrations and descriptions contained in this manual are therefore not binding and are merely indicative.

Le fabricant se réserve la faculté d'apporter, sans préavis, toutes les modifications qu'il jugera utiles pour l'amélioration de ses produits. Les illustrations et les descriptions figurant dans ce manuel ne sont pas contraignantes et n'ont qu'une valeur indicative.

Der Hersteller behält sich vor, ohne vorherige Benachrichtigung alle Änderungen vorzunehmen, die er zur Verbesserung seiner Produkte für nützlich erachtet. Die in diesem Handbuch enthaltenen Illustrationen und Beschreibungen sind daher unverbindlich und dienen nur zur Veranschaulichung.

De fabrikant behoudt zich het recht voor zonder waarschuwing alle wijzigingen aan te brengen die hij nodig acht om zijn producten te verbeteren. De afbeeldingen en de beschrijvingen die aanwezig zijn in deze handleiding zijn niet bindend, en hebben enkel een aanduidende waarde.

El fabricante se reserva el derecho a aportar sin aviso previo todas las modificaciones que considere útiles para la mejora de sus propios productos. Las ilustraciones y las descripciones contenidas en este manual no son vinculantes y tienen solo valor indicativo.

O fabricante reserva-se o direito de efetuar, sem aviso prévio, qualquer modificação que vise o melhoramento dos respetivos produtos. As ilustrações e descrições contidas neste manual não são, por isso, vinculativas e possuem apenas valor indicativo.