

Instruction Manual EN
Microwave

Gebrauchsanweisung DE
Mikrowelle

Руководство по эксплуатации RU
Микроволновой



EN

Dear Customer,

Thank you for choosing this **SMEG** product.

We ask you to read the instructions in this booklet very carefully as this will allow you to get the best results from using it.

KEEP THE DOCUMENTATION OF THIS PRODUCT FOR FUTURE REFERENCE.

Always keep the instruction manual handy. If you lend the appliance to someone else give them the manual as well!

The user manual is also available for download at www.smeg.com

DE

Sehr geehrter Kunde,

Danke dass Sie sich für dieses **SMEG** Gerät entschieden haben.

Wir bitten Sie, die in diesem Heft enthaltenen Anweisungen aufmerksam durchzulesen, die helfen Ihnen, bei der Nutzung Ihres Gerätes die besten Ergebnisse zu erzielen.

BEWAHREN SIE DIE DOKUMENTATION DIESES GERÄTES AUF, UM KÜNFTIG IN IHR NACHSCHLAGEN ZU KÖNNEN.

Halten Sie die Gebrauchsanleitung immer griffbereit. Falls Sie das Gerät Dritten überlassen, stellen Sie ihnen auch die entsprechende Betriebsanleitung zur Verfügung!

Die Gebrauchsanweisung ist auch auf unserer Homepage verfügbar www.smeg.com

RU

Уважаемый клиент,

Благодарим Вас за выбор этого продукта SMEG.

Прежде всего, мы хотим поблагодарить Вас за выбор нашей продукции.

Пожалуйста, внимательно прочитайте инструкции, содержащиеся в данном руководстве, так как они помогут вам добиться лучших результатов при использовании Вашей микроволновой печи.

СОХРАНИТЕ ДОКУМЕНТАЦИЮ ДАННОГО ПРИБОРА ДЛЯ ДАЛЬНЕЙШЕГО ИСПОЛЬЗОВАНИЯ.

Всегда держите Ваше руководство по эксплуатации под рукой. Если Вы даете устройство кому-нибудь другому, не забудьте также дать соответствующее руководство!

Руководство пользователя также доступна для скачивания на www.smeg.com

Contents

1. Instructions	4
1.1. Safety Information	4
1.2. Disposal	9
1.3. This user manual	9
1.4. How to read the user manual	9
2. Description	10
2.1. General Description	10
2.2. Control Panel	11
2.3. Accessories	12
2.4. Description of functions	12
3. Use	13
3.1. Advantages of the microwave oven	13
3.2. Instructions	14
3.3. What kind of ovenware can be used?	14
3.4. First use	16
3.5. Using the oven	16
3.6. Cooking Functions	17
3.7. Special functions and automatic programs	18
3.8. When the oven is working	20
3.9. Secondary menu	21
3.10. Recommended cooking tables	22
4. Cleaning and Maintenance	27
4.1. Instructions	27
4.2. Cleaning the surfaces	27
4.3. Ordinary daily cleaning	27
4.4. Food stains and residues	27
4.5. Cleaning the oven	27
4.6. Extraordinary maintenance	28
4.7. What should I do if the oven doesn't work?	28
5. Installation	29
5.1. Electrical connection	29
5.2. Positioning the oven	29
6. Installation Images	90



Instructions

1.1. Safety Information

Before the installation and use of the appliance, carefully read the supplied instructions. The manufacturer is not responsible if an incorrect installation and use causes injuries and damages. Always keep the instructions with the appliance for future reference.

CHILDREN AND VULNERABLE PEOPLE SAFETY

Warning! Risk of suffocation, injury or permanent disability.

- This appliance can be used by children aged from 8 years and above and persons with reduced physical, sensory or mental capabilities or lack of experience and knowledge if they are supervised by an adult or a person who is responsible for their safety.
- Do not let children play with the appliance.
- Keep all packaging away from children.
- **WARNING:** Keep children away from the appliance when it operates or when it cools down. Accessible parts are hot.
- If the appliance has a child safety device, we recommend that you activate it. Children under 3 years must not be left unsupervised in the vicinity of the appliance.
- Cleaning and user maintenance shall not be made by children without supervision.

GENERAL SAFETY

- This appliance is intended to be used in household and similar applications such as:
 - staff kitchen areas in shops, offices and other working environments;
 - farm houses;
 - by clients in hotels, motels and other residential environments;
 - bed and breakfast type environments.
- Internally the appliance becomes hot when in operation. Do not touch the heating elements that are in the appliance. Always use oven gloves to remove or put in accessories or ovenware.
- **WARNING:** Do not heat liquids and other foods in sealed containers. They are liable to explode.



- Only use utensils that are suitable for use in microwave ovens.
- When heating food in plastic or paper containers, keep an eye on the appliance due to the possibility of ignition.
- The appliance is intended for heating food and beverages. Drying of food or clothing and heating of warming pads, slippers, sponges, damp cloth and similar may lead to risk of injury, ignition or fire.
- **Warning!** The oven cannot be used if:
 - The door is not closed correctly;
 - The door hinges are damaged;
 - The surfaces of the contact between the door and the oven front are damaged;
 - The door window glass is damaged;
 - There is frequent electrical arcing inside the oven even though there is no metal object inside.
- The oven can only be used again after it has been repaired by a Technical Assistance Service technician.
- If smoke is emitted, switch off or unplug the appliance and keep the door closed in order to stifle any flames.
- Microwave heating of beverages can result in delayed eruptive boiling. Care must be taken when handling the container.
- The contents of feeding bottles and baby food jars shall be stirred or shaken and the temperature checked before consumption, in order to avoid burns.
- Eggs in their shell and whole hard-boiled eggs should not be heated in the appliance since they may explode, even after microwave heating has ended.
- **Warning!** Do not heat pure alcohol or alcoholic drinks in the microwave. **FIRE RISK!**
- **Beware!** To avoid food overheating or burning it is very important not to select long time periods or power levels that are too high when heating small quantities of food. For example, a bread roll can burn after 3 minutes if the power selected is too high.



Instructions

- For toasting, use just the grilling function and watch the oven all the time. If you use a combined function to toast bread it will catch fire in a very short time.
- Make sure you never catch the power cables of other electrical appliances in the hot door or the oven. The cable insulation may melt. **Danger of short-circuiting!**



- **Take care when heating liquids!**

When liquids (water, coffee, tea, milk, etc.) are nearly at boiling point inside the oven and are taken out suddenly, they may spurt out of their containers.

DANGER OF INJURIES AND BURNS!

To avoid that type of situation when heating liquids, put a teaspoon or glass rod inside the container.

INSTALLATION

- The electric system must be equipped with a means for disconnection, with a contact separation in all poles that provides full disconnection under overvoltage category III.
- If a plug is used for the electric connection, then it must be accessible after installation.
- Protection against electric shock must be provided by the electrical installation
- Warning: The oven must be earthed.

CLEANING

- The appliance should be cleaned regularly and any food deposits removed.
- Do not use a steam cleaner to clean the appliance.
- Failure to maintain the appliance in a clean condition could lead to deterioration of the surface that could adversely affect the life of the appliance and possibly result in a hazardous situation.



- Do not use harsh abrasive cleaners or sharp metal scrapers to clean the glass door since they can scratch the surface, which may result in shattering of the glass.
- The door contact surfaces (the front of the cavity and the inside part of the doors) must be kept very clean in order to ensure the oven functions correctly.
- Please follow the instructions regarding cleaning in the section "Oven Cleaning and Maintenance".

REPAIRS

- **WARNING:** Before maintenance cut the power supply.
- **WARNING:** Only a competent person can carry out any service or repair operation that involves the removal of a cover which gives protection against exposure to microwave energy.
- **WARNING:** If the door or door seals are damaged, the appliance must not be operated until it has been repaired by a competent person.
- If the power cable is damaged it should be substituted by the manufacturer, authorized agents or technicians qualified for this task in order to avoid dangerous situations. Furthermore, special tools are required for this task.
- Repair and maintenance work, especially of current carrying parts, can only be carried out by technicians authorized by the manufacturer.

Avoid damaging the oven or other dangerous situations by following these instructions:

- Never switch on the microwave when it is empty. If there is no food inside there may be an electrical overcharge and the oven could be damaged. **RISK OF DAMAGE!**
- For carrying out oven programming tests put a glass of water inside the oven. The water will absorb the microwaves and the oven will not be damaged.



Instructions

- Do not cover or obstruct the ventilation openings.
- Use only dishes suitable for microwaves. Before using dishes and containers in the microwave, check that these are suitable (see the section on types of dishes).
- Never remove the mica cover on the ceiling of the oven interior! This cover stops fat and pieces of food damaging the microwave generator.
- Do not keep any inflammable object inside the oven as it may burn if the oven is switched on.
- Do not use the oven as a pantry.
- Do not use the oven for frying as it is impossible to control the temperature of oil heated by microwaves.
- The ceramic base and the grills can bear a maximum load of 8 kg. To avoid damaging the oven, do not exceed this load.



1.2. Disposal

Eliminating the packaging



The packaging carries the Green Dot. Use the right bins when discarding all of the packaging materials, such as the cardboard, styrene and plastic films. This will ensure that the packaging materials are recycled.

Disposal of old electrical appliances



The European Directive 2012/19/EU on Waste Electrical and Electronic Equipment (WEEE), requires that old household electrical appliances must not be disposed of in the normal unsorted municipal waste stream. Old appliances must be collected separately in order to optimise the recovery and recycling of the materials they contain and reduce the impact on human health and the environment.

The crossed out “wheeled bin” symbol on the product reminds you of your obligation, that when you dispose of the appliance it must be separately collected.

Consumers should contact their local authority or retailer for information concerning the correct disposal of their old appliance.

Before you dispose of your appliance, remove the power cable, cut it and dispose of it.

1.3. This user manual

This user manual is an integral part of the appliance and must therefore be kept in its entirety and within the user's reach for the whole working life of the appliance.

- Read this user manual carefully before using the appliance.

1.4. How to read the user manual

This user manual uses the following reading conventions:



Instructions

General Information on this user manual, on safety and final disposal.



Description

Description of the appliance and its accessories.



Use

Information on the use of the appliance and its accessories, cooking advice.



Cleaning and Maintenance

Information for proper cleaning and maintenance of the appliance.



Installation

Information for the qualified technician: Installation, operation and inspection.



Safety Instructions



Information



Advice



Description

2.1. General Description

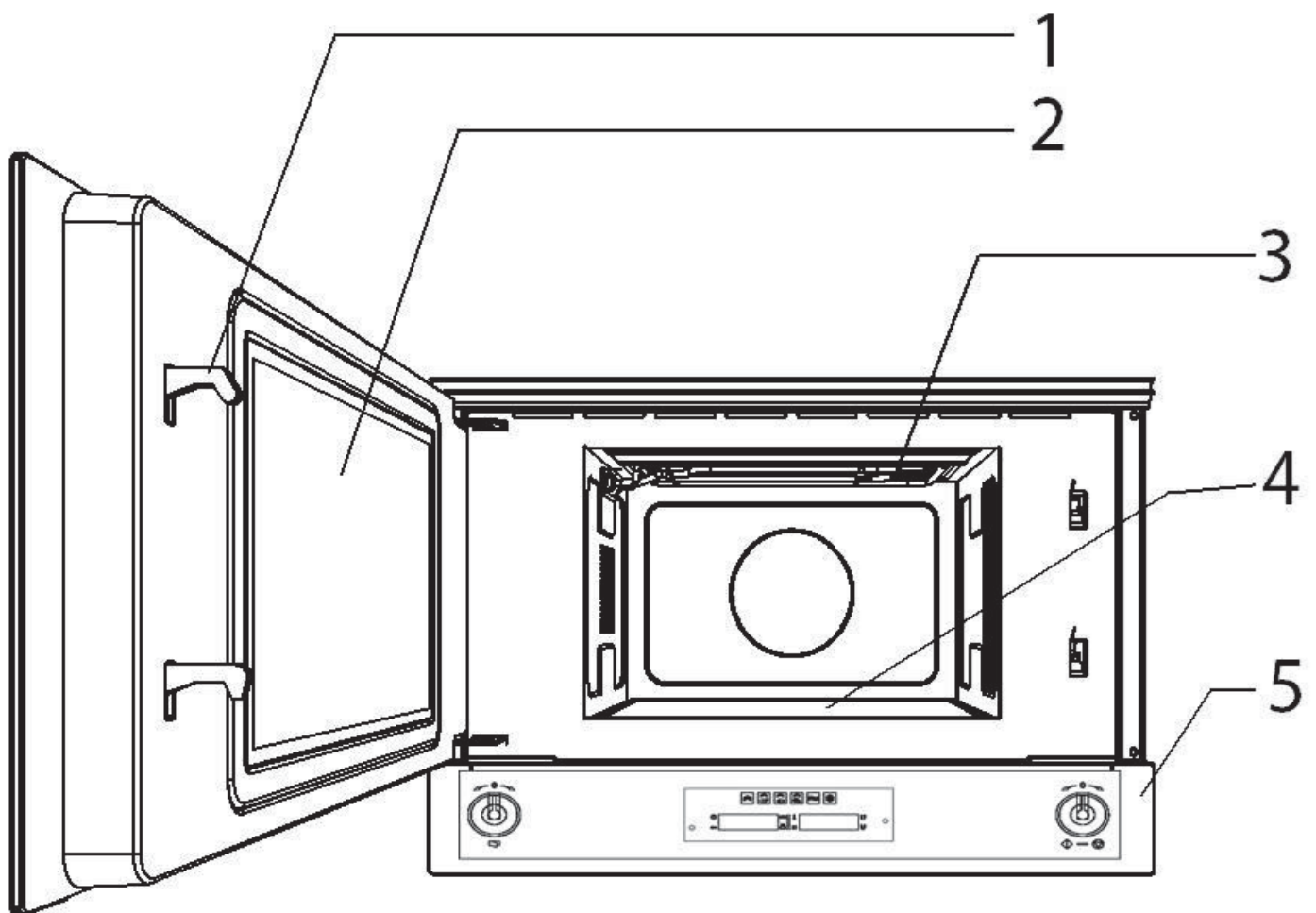

1. Catches
2. Door window glass
3. Drop-down grill
4. Ceramic base
5. Control panel



2.2. Control Panel



1 PT1 Function's parameters knob

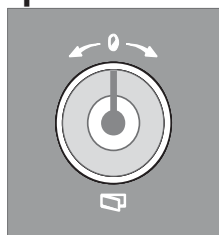

(From now on, for convenience it will be referred to as **PT1**.)

This knob allows you to:

- Open the door
- Set the time
- Select the cooking temperature
- Select the cooking duration
- Program the cooking start and end times.

For instructions on how to use it correctly, see the next chapters.

Note: Parameter knob allows you to open the door by pressing it briefly.

2 DSP1 Current time / Duration display

(From now on, for convenience it will be referred to as **DSP1**.)

This display shows the current time or the cooking duration.

Also visible are the function safety lock-out light (see "Child safety lock-out function")

3 DSP2 Microwaves power / Weight display

(From now on, for convenience it will be referred to as **DSP2**.)

This display shows the Parameters set for the function required, or the Parameters set by the user.

4 DSP3 Function display

(From now on, for convenience it will be referred to as **DSP3**.)

This display shows (illuminated) all the cooking functions available for selection.

For instructions on how to select a cooking function, see point "Operating modes".

5 PT2 Function-switch on knob



(From now on, for convenience it will be referred to as **PT2**.)

This knob allows:

- The switching on and off of the microwave
- To select a cooking function (see "Operating modes").



Description

2.3. Accessories

Rack

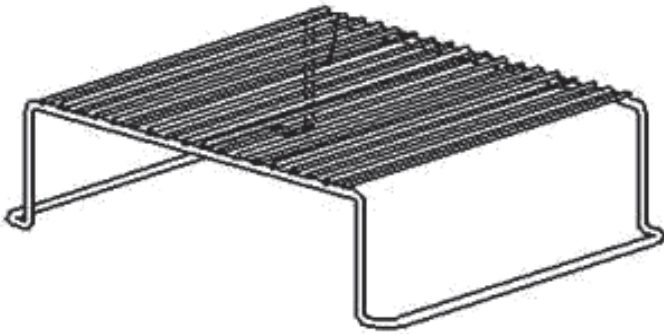

Useful for grilling thin foods useful for grilling foods or other general uses.



Please pay attention to avoid the contact between the grill and the oven cavity during the microwaves function use; It could damage the cavity.



Some models are not provided with all accessories.

2.4. Description of functions

The table below provides a short description of the functions available.



Microwaves



Defrost by time



Microwaves + grill element



Defrost by weight



Grill element



Pizza function



3.1. Advantages of the microwave oven

In a conventional cooker, the heat that is radiated through the resistances or gas burners slowly penetrates the foods from the outside in. Therefore, there is a great loss of energy in heating the air, the oven components and the containers holding the food.

In the microwave, the heat is generated by the foods themselves, i.e. the heat goes from the inside out. There is no loss of heat to the air, the walls of the cavity or the containers (as long as they are microwave-safe containers). This means that only the food is heated.

To sum up, microwave ovens have the following advantages:

1. Savings in cooking time; in general, there is a $\frac{3}{4}$ reduction in time compared to conventional cooking.
2. Ultra fast defrosting of foods, thus reducing the danger of bacteria developing.
3. Energy-saving.
4. Conservation of the nutritional value of foods due to the reduction in cooking time.
5. Easy cleaning.

Microwave oven operating mode

The microwave oven contains a high voltage valve called a Magnetron, which converts the electrical energy into microwave energy. These electromagnetic waves are channelled towards the inside of the oven by a wave guide and distributed using a metallic disperser or a rotating plate.

Inside the oven, the microwaves are propagated in all directions and reflected by the metallic walls, thus uniformly penetrating the foods.

Why the food is heated

Most foods contain water and the water molecules vibrate with the microwaves.

The friction between the molecules generates heat, which raises the temperature of the foods, defrosting or cooking them or keeping them hot.

Because heat is formed inside the foods:

- The foods may be cooked without any liquids or oils, or with very little of these;
- Defrosting, heating or cooking in the microwave oven is faster than in a conventional oven;
- The vitamins, minerals and nutritious substances are conserved;
- Neither the natural colour nor the aroma are altered.

The microwaves go through porcelain, glass, cardboard or plastic, but not through metal. For this reason, metallic containers or containers with metallic parts should not be used in the microwave oven.

Microwaves are reflected by metal...

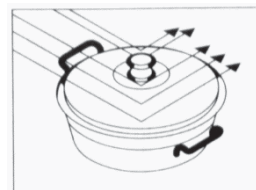

... they go through glass and porcelain...

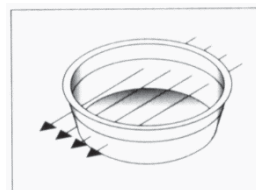

... and are absorbed by the foods.

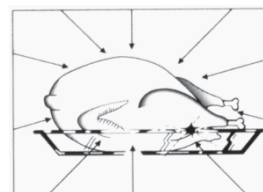



Use

3.2. Instructions



High temperature inside the oven during use

Danger of fire or explosion

- Do not spray any products near the oven.
- Do not use or leave flammable materials near the oven.
- Do not use plastic kitchenware to cook food (except with the microwave function).
- Do not put sealed tins or containers in the oven.
- Do not leave the oven unattended during cooking operations where fats or oils could be released.
- Remove all trays and racks which are not required during cooking

3.3. What kind of ovenware can be used?

Microwave function

In the microwave function, it is important to remember that the microwaves are reflected by metallic surfaces. Glass, porcelain, ceramic, plastic and paper will allow the microwaves to pass through.

Therefore, **metallic pans and dishes for cooking or containers with metallic components or decorations may not be used in the microwave.** Glassware and ceramic with **metallic decorations or parts** (e.g. lead glass) may not be used.

The **ideal** materials to be used for cooking in a microwave oven are refractory, heat-resistant glass, porcelain or ceramic. Very fine crystal and porcelain should only be used for a short time, to defrost or reheat foods that have already been cooked.

Test the dishes

Place the dish inside the oven at the maximum power level for 20 seconds. If it is cold or not very hot, it is suitable. However, if it gets very hot or causes an electrical arch, it is not suitable.

Hot foods transmit heat to the dish, which may become very hot. Therefore, always use a **glove!**

Grill function

In the case of the grill function, the dish must be resistant to temperatures of at least 250°C.

Plastic dishes are not suitable.

Combined function

In the combined function, the dishes that are used must be suitable for both microwave and grill cooking.

Aluminium containers and foils

Precooked foods in aluminium containers or wrapped in aluminium foil may be placed in the microwave oven if the following instructions are followed:

- Pay attention to the manufacturer's instructions that are printed on the packaging,
- Aluminium containers should not be higher than 3 cm and they should not come into contact with the walls of the cavity (minimum distance 3 cm). The aluminium lid should be removed.
- Place the aluminium container directly on the ceramic base. If the grille is used, the container should be placed on a porcelain plate. Never put the container directly on the grille!
- The cooking time will be longer because the microwaves only enter the food from above. In case of doubt, only use microwave-safe dishes.
- Aluminium foil may be used to reflect the microwaves during the defrosting process. Delicate foods, such as poultry or minced meat, may be protected from excessive heat by covering the respective ends.
- **Important:** the aluminium foil must not come into contact with the walls of the cavity, as this could cause an electrical arch.



Lids

The use of glass or plastic lids or adherent film is recommended, for the following reasons:

1. They prevent excessive evaporation (especially in very long cooking periods);
2. The cooking process is faster;
3. The food does not go dry;
4. The aroma is preserved.

The lid should have holes to avoid any type of pressure from building up. Plastic bags should also have openings. Baby bottles and baby food jars and other similar containers must only be heated without the lid, as they might explode if it is left on.

The following table gives general guidelines on the type of dishes that are suitable for each situation.

Table – dishware

Operating mode Type of dish	Microwave		Grill	Microwave + Grill
	Defrost / heat	Cook		
Glass and porcelain 1) Domestic, non fire-resistant, may be washed in dishwasher	yes	yes	no	no
Glazed ceramic Fire-resistant glass and porcelain	yes	yes	yes	yes
Ceramic, earthenware dishes unglazed glazed without metallic decorations	yes	yes	no	no
Earthenware dishes glazed unglazed	yes no	yes no	no no	no no
Plastic dishes 2) heat-resistant up to 100°C heat-resistant up to 250°C	yes yes	no yes	no no	no no
Plastic films 3) Cling film Cellophane	no yes	no yes	no no	no no
Paper, cardboard, parchment 4)	yes	no	no	no
Metal Aluminium foil Aluminium containers 5) Accessories	yes no yes	no yes yes	yes yes yes	no yes yes

1. No golden or silver edges and no lead glass.
2. Remember the manufacturer's tips!
3. Do not use metal clips to close the bags. Perforate the bags. Use films only to cover foods.

4. Do not use paper plates.
5. Only shallow aluminium containers without lids. The aluminium must not come into contact with the walls of the cavity.



Use

3.4. First use

1. Remove any protective film from the outside or inside of the appliance, including accessories.
2. Remove any labels (apart from the rating plate) from the accessories and from the oven cavity.
3. Remove and wash all the appliance accessories (see 4 Cleaning and Maintenance).
4. Heat the empty oven at maximum temperature (using traditional functions) so as to remove any manufacturing residues.



For the first heating use a traditional function and not a microwave function.

3.5. Using the oven

Opening the door

To open the door press PT1 briefly.

Operating modes

This product is programmed to provide 3 operating settings, which can be modified by pressing PT2.

Stand-by: activated as soon as the current time has been confirmed, with DSP1 on and showing the current time



ON: from the standby setting, press PT2 once. All the displays and knobs light up.



OFF: from the ON setting, press PT2 once. Only the symbol on DSP1 remains on.



The heating system is not activated immediately in any of these functions, in order to improve operator safety.

Setting the time

On the first use, or after a power failure will be flashing on the appliance's display. To be able to start any cooking function, the current time must be set.

1. Press PT1 for 3 seconds to set the current time.
2. Turn PT1 to the right and left to increase or decrease the hours.
3. Press it once to move on to setting the minutes.
4. Turn it the right and left to increase or decrease the hours and press it to set the current time.
5. The symbol will appear on the display, which will stop flashing.
6. Press PT1 again and the minutes will Flash, turn right left to set the minutes.
7. Press PT and the time is set.

Setting the current time

It might become necessary to change the current time, for example at the switch from summer to winter time. To do this, start from the standby setting (see "Operating modes"). Now repeat the operations described in point "Setting the time".



It is not possible to change the time if the oven is **ON**.

Selecting the function

1. In the ON state only, a cooking function can be selected by simply turning PT2 to the right or left.
2. The function selected will change colour to orange on DSP3.
3. The preset cooking time will be displayed on DSP1 and the preset parameters (temperature, microwaves power, weight) are displayed in alternation on DSP2.



3.6. Cooking Functions

Microwave



Given that they penetrate directly into the food, microwaves allow cooking to take place in a very short period of time and with a considerable saving of energy. They are suitable for cooking without fat and also for defrosting and re-heating food while maintaining its original appearance and fragrance.

1. After selecting this function, turn PT1 to the right or left to change the preset cooking duration.
2. Press PT1 for 3 seconds to validate and the microwaves power light **W** starts to blink.
3. Turn PT1 to the right or left to change the preset microwaves power.
4. Press PT2 to immediately start the cooking process or otherwise press PT1 for 3 seconds to set a different time for the cooking process start (please refer to “Delayed Start Time (Automatic cooking)”).



If the door is opened then cooking will stop. Once the door is closed press the **START** key to resume cooking.

Combination



Combination cooking is a mix of traditional cooking and microwave operation.

Microwave + Grill



The use of the grill results in perfect browning of the food's surface. Using the microwave on the other hand leads to a rapid internal cooking of the food.

1. After selecting this function, turn PT1 to the right or left to change the preset cooking duration.
2. Press PT1 for 3 seconds to validate and the microwaves power light **W** starts to blink.
3. Turn PT1 to the right or left to change the preset microwaves power.
4. Press PT2 to immediately start the cooking process or otherwise press PT1 for 3 seconds to set a different time for the cooking process start (please refer to “Delayed Start Time (Automatic cooking)”).



Improper user

Risk of damages to the appliance

- Do not use the combined functions to heat or boil liquids.



Use

Traditional cooking functions

Grill



The heat coming from the grill element gives perfect grilling results above all for thin and medium thickness meat and allows you to give the food an even browning at the end of the cooking. Perfect for sausages, spare ribs and bacon.

This function enables large quantities of food, particularly meat, to be grilled evenly.

1. After selecting this function, turn PT1 to the right or left to change the preset cooking duration.
2. Press PT2 to immediately start the cooking process or otherwise press PT1 to set a different time for the cooking process start (please refer to “Delayed Start Time (Automatic cooking)”).

3.7. Special functions and automatic programs

Defrosting by time (manual)



This function allows food to be defrosted by the microwave according to a selected period of time.

1. After selecting this function, turn PT1 to the right or left to change the preset defrosting duration.
2. Press PT2 to start the defrosting process.
3. The microwaves power will be automatically varied to achieve the best thawing results.



If the selected defrost duration is more than 5 minutes then, for best results, the dish inside the oven compartment will need to be turned.



Defrosting by weight (automatic)



This function allows food to be microwave defrosted according to the weight and type of food to be defrosted.

1. After selecting this function, turn PT1 to the right or left to change the preset food type displayed on DSP1.
2. Press PT1 for 3 seconds to validate and the weight light starts to blink.
3. Turn PT1 to the right or left to change the preset food weight.
4. Press PT2 to start the defrosting process.
5. The defrosting time will be calculated based on the food's type and weight and the microwaves power will be automatically varied to achieve the best thawing results.



For best results during defrosting the dish inside the oven will need to be turned.

The following table shows the programs for the defrosting by weight function, indicating the weight ranges, defrosting and resting times (to ensure that the food reaches a uniform temperature).

Program	Food	Weight (kg)	Time (min)	Resting time (min)
PR-01	Meat	100 - 2000	2 - 43	20 - 30
PR-02	Poultry	100 - 2500	2 - 58	20 - 30
PR-03	Fish	100 - 2000	2 - 40	20 - 30
PR-04	Fruit	100 - 500	2 - 13	5 - 10
PR-05	Bread	100 - 800	2 - 19	5 - 10

Pizza function



1. Turn PT2 to the right or left to select the Pizza Function.
2. The Pizza Function indicator will be highlighted and DSP2 shows the pre-set time of 7 minutes.
3. This pre-set time is indicated to cook handmade pizzas and frozen pizzas up to 26 cm diameter, with an approximate weight of 350g and whose temperature is above 5°C.



In order to ensure satisfactory cooking result for frozen pizzas you should allow them to thaw and reach at least 5°C.



Use

Delayed Start Time (Automatic cooking)

1. When PT1 is pressed to define a delayed start time the corresponding light  starts to blink, DSP1 shows the current time and DSP 2 shows "Auto".
2. Turn PT1 to the right or left to change the delayed start time.
3. Press PT2 to validate the delayed start time.
4. The oven enters in an idle state waiting for the defined start time. DSP3 shows the selected function and DSP1 and DSP2 show all the defined parameters for the function continuously alternating.
5. If you wish to start the function before the selected time, just press PT2.
6. If you wish to cancel the programming, press PT2 for 3 seconds.

3.8. When the oven is working...

Interrupting a cooking cycle

You can stop the cooking process at any time by pressing the Start/Stop key once or by opening the oven door. In both cases:

- **Microwave emission is stopped immediately.**
- The grill is de-activated but is **still very hot. Danger of burning!**
- The timer stops and the display shows the remaining amount of operating time.

If you wish, at this time you can:

- Turn or stir the food to ensure it will be evenly cooked.
- Modify the process parameters.
- Cancel the process by pressing PT2 for 3 seconds.

To restart the process, close the door and press PT2.

Modifying parameters

The operating parameters (time, weight, power, etc.) can only be modified when the cooking process has been interrupted. Proceed as follows:

- Press PT1 approximately 5-6 seconds to activate the parameter modification mode. The  symbol starts to blink. Turn PT1 to the right or left to change the remaining cooking duration.
- Press PT1 for 3 seconds to validate and the next parameter light starts to blink. Proceed as described in the active function chapter to modify the remaining parameters.
- Press PT2 to continue the cooking process.

Cancelling a cooking cycle

1. If you wish to cancel the cooking process, press PT2 for 3 seconds.
2. You will then hear a beep and the oven returns to the OFF setting.

End of a cooking cycle

At the end of the process you will hear three beeps and the display will show the word "End".

The beeps are repeated every 30 seconds until the door is opened or PT2 is pressed. The oven returns to the OFF setting





3.9. Secondary menu

This appliance also has a concealed "secondary menu" allowing the user to:

1. Activate or deactivate the Show Room function (which disables all the heating elements so that only the control panel works);
2. Activate or deactivate the function which limits the maximum power absorption to 2000 W;
3. Activate or deactivate the child safety device ();

Child safety lock-out function

1. With the oven in OFF status (see "Operating modes") keep PT1 pressed until the message OFF SHO appears on DSP1.
2. Now press PT1 until the message "OFF BLOC" appears on DPS1.
3. Turn PT1 to the right or left to activate (ON BLOC) or deactivate (OFF BLOC) this function, which locks out all the functions and knobs after 3 minutes of operation without any command from the user (when this system is active, the  symbol appears on DPS2).
4. After setting the parameter required, press PT2 to return the oven to the initial standby status.
5. To exit the lockout status temporarily to modify a cooking program or select a different function, keep PT1 pressed until the  symbol disappears from DSP2. The required changes can now be made, and 2 minutes after the last setting is made the lockout will come into operation again.
6. To deactivate the lockout permanently, access the secondary menu and switch the function off as described in this section.

Show Room Function (for exhibitors only)

1. With the oven in OFF status (see point "7.2 Operating settings") keep PT1 pressed between 5-6 seconds, until the message OFF SHO appears on DSP1. This means that the SHOW ROOM function (which disables all the heating elements so that only the control panel works) is not active.
2. Turn PT1 to the right or left to activate (ON SHO) or deactivate (OFF SHO) this function. To use the oven normally, set OFF SHO.
3. After setting the parameter required, press PT2 to return the oven to the initial standby status.

Cooling fan system

The appliance is equipped with a cooling system which comes into operation as soon as a cooking function starts.

Operation of the fans generates a normal air flow which comes out above the door and may continue for a short time even after the oven is switched off.

Inside light

The oven light comes on:

- when the oven door is opened in standby status or;
- when the function knob is turned to any function.

If the oven door is left open, the oven light will automatically shut-off after 10 minutes.



3.10. Recommended cooking tables

Cooking with Microwaves



Warning!

- Read the section “Safety Information” before cooking with your microwave

Follow these recommendations when cooking with microwaves:

- Before heating or cooking foods with peel or skin (e.g. apples, tomatoes, potatoes, sausages) prick them so that they do not burst. Cut the food up before starting to prepare it.
- Before using a container or dish make sure that it is suitable for microwave use (see the section on types of ovenware).
- When cooking food with very little moisture (e.g. defrosting bread, making popcorn, etc.) evaporation is very quick. The oven then works as if it was empty and the food may burn. The oven and the container may be damaged in such a situation. You should therefore set just the cooking time necessary and you must keep a close eye on the cooking process.
- It is not possible to heat large quantities of oil (frying) in the microwave.
- Remove pre-cooked food from the containers they come in since these are not always heat resistant. Follow the food manufacturer's instructions.
- If you have several containers, such as cups, for example, set them out uniformly on the ceramic base.
- Do not close plastic bags with metal clips. Use plastic clips instead. Prick the bags several times so that the steam can escape easily.
- When heating or cooking foods, check that they reach at least a temperature of 70°C.
- During cooking, steam may form on the oven door window and may start to drip. This

situation is normal and may be more noticeable if the room temperature is low. The oven's safe working is not affected by this. After you have finished cooking, clean up the water coming from the condensation

- When heating liquids, use containers with a wide opening, so that the steam can evaporate easily.

Prepare the foods as per the instructions and keep in mind the cooking times and power levels indicated in the tables.

Keep in mind that the figures given are only indicative and can vary depending on the initial state, temperature, moisture and type of food. It is advisable to adjust the times and power levels to each situation. Depending on the exact characteristics of the food you may need to increase or shorten the cooking times or increase or decrease the power levels.

Cooking with microwaves...

1. The greater the amount of food, the longer the cooking time. Keep in mind that:
 - Double the quantity » double the time
 - Half the quantity » half the time
2. The lower the temperature, the longer the cooking time.
3. Foods containing a lot of liquid heat up more quickly.
4. Cooking will be more uniform if the food is evenly distributed on the ceramic base. If you put dense foods on the outside part of the plate and less dense ones on the centre of the plate, you can heat up different types of food simultaneously.
5. You can open the oven door at any time. When you do this the oven switches off automatically. The microwave will only start working again when you close the door and press the start key.
6. Foods that are covered require less cooking time and retain their characteristics better. The lids used must let microwaves pass through and have small holes that allow steam to escape



Cooking vegetables

Food	Quantity (gr)	liquids Addition	Power (W)	Time (min.)	Standing Time (min.)	Instructions
Cauliflower	500	100 ml	850	9-11	2-3	Cut into slices. Keep covered.
Broccoli	300	50 ml	850	6-8	2-3	
Mushrooms	250	25 ml	850	6-8	2-3	
Peas, carrots	300	100 ml	850	7-9	2-3	Cut into chunks or slices. Keep covered.
Frozen carrots	250	25 ml	850	8-10	2-3	
Potatoes	250	25 ml	850	5-7	2-3	Peel and cut into equal sized pieces. Keep covered.
Paprika	250	25 ml	850	5-7	2-3	Cut into chunks or slices. Keep covered.
Leek	250	50 ml	850	5-7	2-3	
Frozen Brussel sprouts	300	50 ml	850	6-8	2-3	Keep covered.

Cooking fish

Food	Quantity (g)	Power (W)	Time (min.)	Standing Time (min.)	Instructions
Fish fillets	500	600	10-12	3	Cook covered over. Turn after half of cooking time.
Whole fish	800	850	2-3	2-3	Cook covered over. Turn after half of cooking time. You may wish to cover up the small edges of the fish.
		360	7-9		

Defrosting with Microwaves



General instructions for defrosting:

1. When defrosting, use only dishes that are appropriate for microwaves (china, glass, suitable plastic).
2. The defrost function by weight and the tables refer to the defrosting of raw food.
3. The defrosting time depends on the quantity and thickness of the food. When freezing food keep the defrosting process in mind. Distribute the food evenly in the container.
4. Distribute the food as best as possible inside the oven. The thickest parts of fish or chicken

drumsticks should be turned towards the outside. You can protect the most delicate parts of food with pieces of aluminium foil. Important: The aluminium foil must not come into contact with the oven cavity interior as this can cause electrical arcing.

5. Thick portions of food should be turned several times.
6. Distribute the frozen food as evenly as possible since narrow and thin portions defrost more quickly than the thicker and broader parts.

7. Fat-rich foods such as butter, cream cheese and cream should not be completely defrosted. If they are kept at room temperature they will be



Use

ready to be served in a few minutes. With ultra-frozen cream, if you find small pieces of ice in it, you should mix these in before serving.

8. Place poultry on an upturned plate so that the meat juices can run off more easily.

9. Bread should be wrapped in a napkin so that it does not become too dry.

10. Turn the food whenever the oven lets out a beep and the DSP1 displays the word: *turn*.

11. Remove frozen food from its wrapping and do not forget to take off any metal twist-tags. For containers that are used to keep frozen food in the freezer and which can also be used for heating and cooking, all you need to do is take off the lid.

For all other cases you should put the food into containers that are suitable for microwave use.

12. The liquid resulting from defrosting, principally that from poultry, should be discarded. In no event should such liquids be allowed to come into contact with other foods.

13. Do not forget that by using the defrosting function you need to allow for standing time until the food is completely defrosted.

The table below shows different defrosting and standing times (in order to ensure the food temperature is evenly distributed) for different types and weights of food, plus recommendations.

Food	Weight (g)	Defrosting time (min)	Standing time (min)	Recommendation
Portions of meat, veal, beef, pork	100	2-3	5-10	Turn once
	200	4-5	5-10	Turn once
	500	10-12	10-15	Turn twice
	1000	21-23	20-30	Turn twice
	1500	32-34	20-30	Turn twice
	2000	43-45	25-35	Turn three times
Goulash	500	8 -10	10-15	Turn twice
	1000	17-19	20-30	Turn three times
Minced meat	100	2-4	10-15	Turn twice
	500	10-14	20-30	Turn three times
Sausages	200	4-6	10-15	Turn once
	500	9-12	15-20	Turn twice
Poultry (portions)	250	5-6	5-10	Turn once
	1000	20-24	20-30	Turn twice
Chicken	2500	38-42	25-35	Turn three times
Poularde	200	4-5	5-10	Turn once
Fish fillet	250	5-6	5-10	Turn once
Trout	100	2-3	5-10	Turn once
Prawns	500	8-11	15-20	Turn twice
Fruit	200	4-5	5-10	Turn once
	300	8-9	5-10	Turn once
	500	11-14	10-20	Turn twice
Bread	200	4-5	5-10	Turn once
	500	10-12	10-15	Turn once
	800	15-17	10-20	Turn twice
Butter	250	8-10	10-15	
Cream cheese	250	6-8	10-15	
Creams	250	7-8	10-15	



Cooking with the Grill Element

For good results with the grill, use the rack supplied with the oven.

Fit the rack in such a way that it doesn't come into contact with the metal surfaces of the oven cavity since if it does there is a danger of electric arcing which may damage the oven.

IMPORTANT POINTS:

1. When the grill is used for the first time there will be some smoke and a smell coming from the oils used during oven manufacture.
2. The oven door window becomes very hot when the grill is working. Keep children away.
3. When the grill is operating, the cavity walls and the grid iron become very hot. You should use oven gloves.

4. If the grill is used for extended period of time it is normal to find that the elements will switch themselves off temporarily due to the safety thermostat.

5. Important! When food is to be grilled or cooked in containers you must check that the container in question is suitable for microwave use. See the section on types of ovenware!

6. When the grill is used it is possible that some splashes of fat may go onto the elements and be burnt. This is a normal situation and does not mean there is any kind of operating fault.

7. After you have finished cooking, clean the interior and the accessories so that cooking remains do not become encrusted.

Grill Element

Fish	Quantity (g)	Time (min.)	Instructions
Fish			
Bass	800	18-24	Spread lightly with butter. After half of cooking time turn and spread with seasoning.
Sardines/gurnard	6-8 fish.	15-20	
Meat			
Sausages	6-8 units	22-26	Prick after half cooking time and turn.
Frozen hamburgers	3 units	18-20	
Spare rib (approx. 3 cm thick)	400	25-30	After half of cooking time, baste and turn.
Others			
Toast	4 units	1½-3	Watch toasting.
Toasted sandwiches	2 units	5-10	Watch toasting.

Heat up the grill beforehand for 2 minutes. Unless indicated otherwise, use the rack. Place a tray below the rack so that the water and the fat can drop. The times shown are merely indicative and can vary as a function of the composition and quantity of the food, as well as the final condition wished for. Fish and meat taste great if, before grilling, you brush them with vegetable oil, spices and herbs and leave to marinate for a few hours. Only add salt after grilling.

Sausages will not burst if you prick them with a fork before grilling.

After half the grilling time has passed, check on how the cooking is going and, if necessary, turn the food over.

The grill is especially suitable for cooking thin portions of meat and fish. Thin portions of meat only need to be turned once, but thicker portions should be turned several times. Heat up the grill beforehand for 2 minutes.



Use

Microwaves + Grill Element

The microwave + grill function is ideal for cooking quickly and, at the same time, browning foods. Furthermore, you can also grill and cook cheese covered food.

The microwave and the grill work simultaneously. The microwave cooks and the grill toasts.

Food	Quantity (g)	Dish	Power (W)	Time (min.)	Standing time (min.)
Cheese topped pasta	500	Low dish	180	12-17	3-5
Cheese topped potatoes	800	Low dish	600	20-22	3-5
Lasagne	approx. 800	Low dish	600	15-20	3-5
Grilled cream cheese	approx. 500	Low dish	180	18-20	3-5
2 fresh chicken legs (grilled)	200 each	Low dish	360	10-15	3-5
Chicken	approx. 1000	Low and wide dish	360	35-40	3-5
Cheese topped onion soup	2 x 200 g cups	Soup bowls	360	2-4	3-5

Before using a dish in the microwave oven make sure that it is suitable for microwave use. Only use dishes or containers that are suitable for microwave use.

The dish to be used in the combined function must be suitable for microwave and grill use. See the section on types of ovenware!

Keep in mind that the figures given are merely indicative and can vary as a function of the initial state, temperature, moisture and type of food.

If the time is not enough to brown the food well, put it under the grill for another 5 or 10 minutes.

Please follow the standing times and don't forget to turn the meat pieces.

Unless indicated to the contrary, use the ceramic base for cooking.

The values given in the tables are valid when the oven cavity is cold (it is not necessary to pre-heat the oven).



4.1. Instructions



High temperature inside the oven after use

Danger of burns

- Perform cleaning only after letting the appliance cool down.



Improper use

Risk of damage to surfaces

- Do not use a steam jet to clean the appliance.
- Do not use cleaning products containing chlorine, ammonia or bleach on steel parts or parts with metallic finishes on the surface (e.g. anodizing, nickel or chromium-plating).
- Do not use abrasive or corrosive detergents on glass parts (e.g. powder products, stain removers and metallic sponges).
- Do not use rough or abrasive materials or sharp metal scrapers.
- Failure to clean the oven could adversely affect the life of the appliance and pose a hazard.
- Always remove food residues from the oven compartment.



Improper user

Danger of explosion/ burns

- Do not use detergents with high alcohol content or which can release inflammable vapours. Subsequent heating could set off an explosion inside the appliance.



Before cleaning the microwave, ENSURE THAT THE PLUG IS NOT IN THE SOCKET.

4.2. Cleaning the surfaces

To keep the surfaces in a good condition, they should be cleaned regularly after use. Let them cool first.

4.3. Ordinary daily cleaning

Always use only specific products that do not contain abrasive or chlorine-based acids.

Pour the product onto a damp cloth and wipe the surface, rinse thoroughly and dry with a soft cloth or a microfiber cloth.

4.4. Food stains and residues

Do not use metallic sponges or sharp scrapers as they will damage the surfaces.

Use ordinary non-abrasive products with the aid of wooden or plastic utensils if necessary. Rinse thoroughly and dry with a soft cloth or a microfiber cloth.

4.5. Cleaning the oven

Cleaning the oven Cavity

Cleaning is the only maintenance normally required.

After each time the oven is used, clean the inside walls with a damp cloth since this is the easiest way to remove splashes or spots of food that may have stuck to the inside.

To remove dirt that is harder to shift, use a non-aggressive cleaning product. Do not use oven sprays or other aggressive or abrasive cleaning products.

Always keep the door and the oven front very clean to ensure that the door opens and closes properly.

Make sure water does not enter the microwave ventilation holes.

Regularly take out the ceramic base and the respective support and clean the cavity base, especially after any liquid spillage.

If the oven cavity is very dirty, put a glass of water on the ceramic base and switch on the microwave oven for 2 or 3 minutes at maximum power. The steam released will soften the dirt which can then be cleaned easily using a soft cloth.

Unpleasant odours (e.g. after cooking fish) can be eliminated easily. Put a few drops of lemon juice in a cup with water. Put a spoonful of coffee in the cup to avoid the water boiling over. Heat the water for 2 to 3 minutes at maximum microwave power.



Cleaning and Maintenance

Cleaning the cavity ceiling

If the oven ceiling is dirty, the grill can be lowered to make cleaning easier.

To avoid the danger of burning, wait until the grill is cold before lowering it.

Proceed as follows:

1. Turn the grill support by 180° (1).
2. Lower the grill gently (2). Do not use excessive force as this may cause damage.
3. After cleaning the ceiling, put the grill (2) back in its place, carrying out the previous operation.

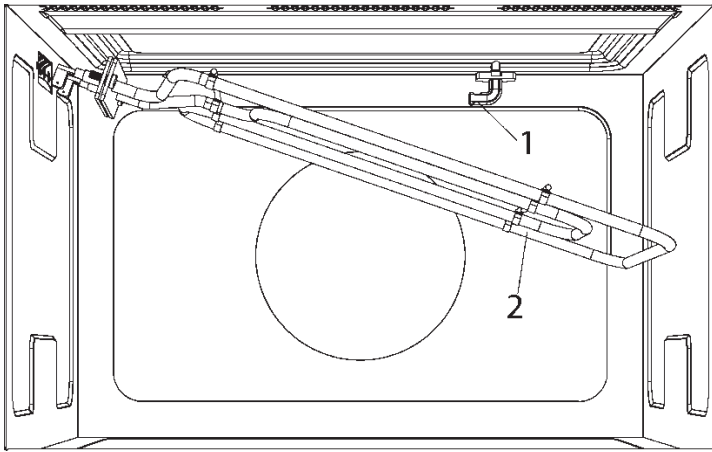

Important Warning!

- The grill heating element support (1) may fall when it is rotated. If this happens, insert the grill heating element support (1) into the slot in the ceiling of the cavity and rotate it 90° to the grill heating element support (2) position.

Cleaning the accessories

Clean the accessories after each use. If they are very dirty, soak them first of all and then use a brush and sponge. The accessories can be washed in a dish washing machine.

Make sure that the ceramic base is always clean.

4.6. Extraordinary maintenance

Occasionally, the oven will require minor servicing procedures or the replacement of parts subject to wear and tear, such as gaskets, light bulbs, etc. The specific operations for each procedure of this kind are provided below.



Before carrying out any operation involving access to live parts, disconnect the appliance from the electricity supply.

Substitution of light bulb

- If the light bulb needs substitution call the Technical Assistance since it is necessary to uninstall the oven to replace it.

4.7. What should I do if the oven doesn't work?



Warning!

- Any type of repair must only be done by a specialised technician. Any repair done by a person not authorised by the manufacturer is dangerous.

You do not need to contact Technical Assistance to resolve the following questions:

The display is not showing! Check if:

- The time indication has been switched off (see section on Use).

Nothing happens when I press the keys! Check if:

- The Safety Block is active (see section on Use).

The oven does not work! Check if:

- The plug is correctly fitted in the socket.
- The oven's power is switched on.
- The door is completely closed. The door should close with an audible click.
- There are any foreign bodies between the door and the cavity front.



When the oven is operating I can hear some strange noises! Check if:

- There is any electrical arcing inside the oven caused by foreign metallic objects (see section on type of ovenware).
- The ovenware is touching the oven walls.
- There are any loose items of cutlery or cooking tools inside the oven.

The food doesn't heat up or heats very slowly! Check if:

- You have inadvertently used metal ovenware.
- You have selected the correct operating times and power level.
- The food you have put inside the oven is a larger amount or colder than you usually put in.

The food is too hot, dried out or burnt! Check if:

- You selected the correct operating time and power level.

I hear some noises after the cooking process is finished!

- This is not a problem. The cooling fan keeps on working for some time. When the temperature has dropped sufficiently, the fan will switch itself off.

The oven switches on but the interior light does not go on!

- If all the functions work properly it is probable that the lamp has blown. You can keep on using the oven.

5.1. Electrical connection

- The nameplate with the technical data, serial number and mark is in a visible position on the oven door frame.
- The nameplate must never be removed.
- The appliance must be connected to earth in compliance with electrical system safety regulations
- If a permanent connection is used, the appliance's power supply line must be fitted with an omnipolar breaking device with contact gap of at least 3 mm, located in an easily accessible position close to the appliance itself.
- If a socket and plug connection is used, check that they are of the same type. Do not use reducers, adapters or junctions since they may cause overheating or burns.

5.2. Positioning the oven

The appliance is designed for building-in to cabinets made from any heat-resistant material. Comply with the dimensions shown in following pictures (see 6. Installation Images).

When installing in tall units bear in mind that the top/rear of the unit must have an opening 100 mm deep.



If the problem has not been resolved or in the case of other types of fault, contact your local technical support centre.



All repairs must be performed by specialised technicians.



Installation Images/ Installations-Images / Установочные образы

EN This microwave is designed to be installed above 850mm from floor level. This microwave cannot be installed under a worktop or below another oven, in order to avoid liquid spillage.

DE Diese Mikrowelle ist darauf ausgelegt, auf mehr als 85 cm Höhe über dem Boden installiert zu werden. Diese Mikrowelle darf nicht unter einer Arbeitsplatte oder unter einem anderen Ofen installiert werden, damit keine Flüssigkeiten darauf auslaufen können.

RU Данная микроволновая печь должна располагаться выше 850 мм от уровня пола. Чтобы избежать попадания жидкости в микроволновую печь, не располагайте микроволновую печь под кухонным столом или другой печью.

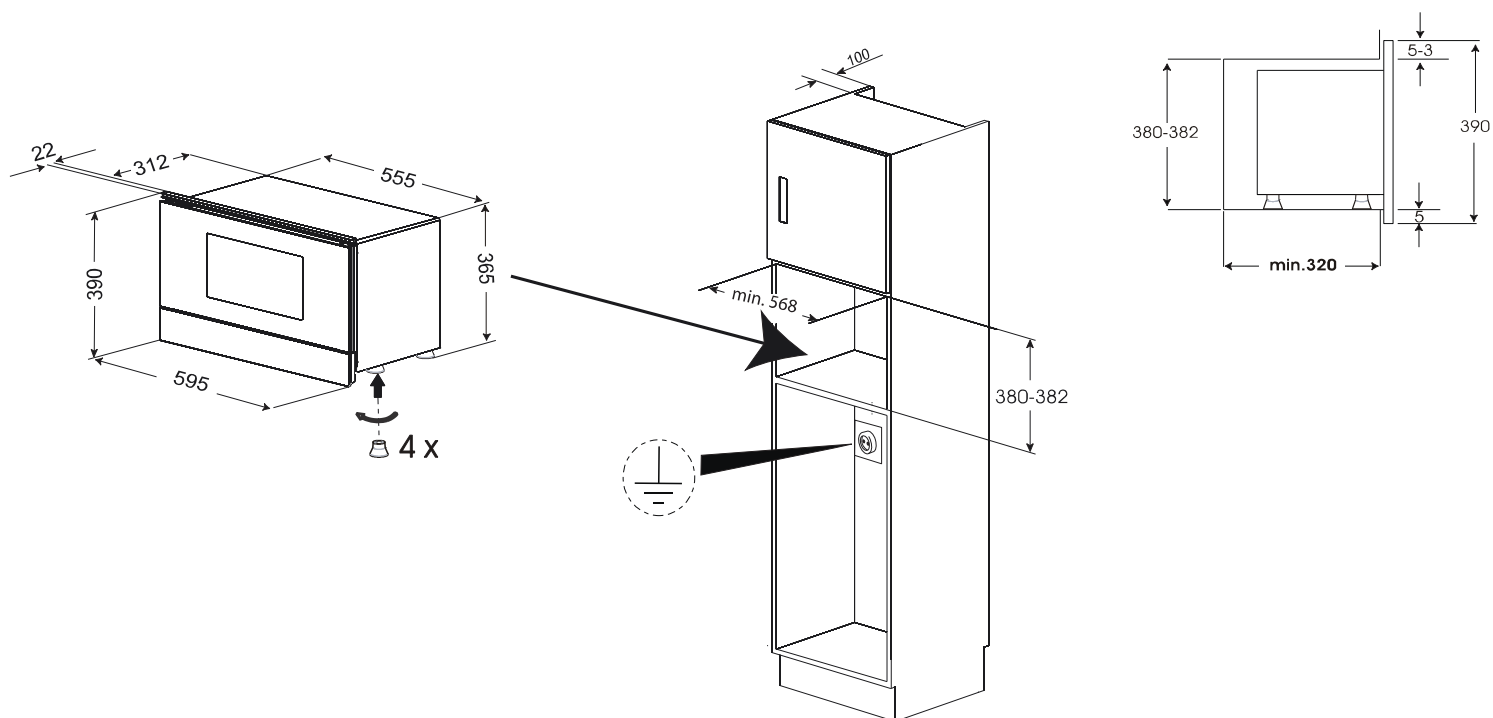
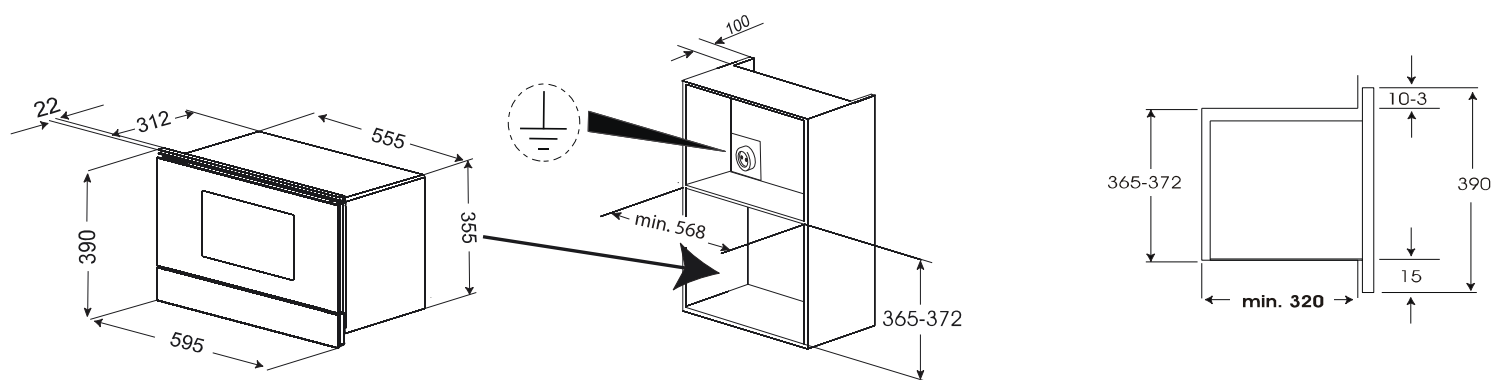

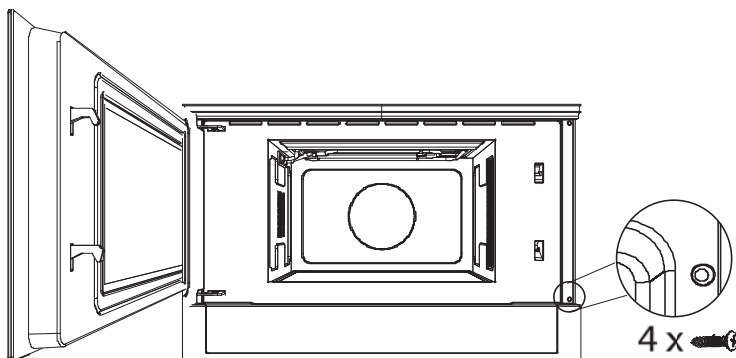

EN

- Push oven completely into the cabinet and centre it.
- Open microwave door and fasten the appliance to the cabinet using the four screws provided.

DE

- Die Mikrowelle in die Nische einschieben und entsprechend anpassen.
- Die Tür der Mikrowelle öffnen und das Gerät mit den vier mitgelieferten Schrauben am Küchenmöbel wie im Bild dargestellt befestigen.

RU

- Разместите печь полностью внутри шкафа по центру ниши.
- Откройте дверцу печи и прикрутите прибор к шкафу при помощи четырех входящих в комплект винтов. Винты вставляйте через отверстия на передней панели.

