

Contents

1	Instructions	22
1.1	Introduction	22
1.2	User Manual	22
1.3	Intended use	22
1.4	General safety instructions	23
1.5	Manufacturer liability	25
1.6	Identification plate	25
1.7	Disposal	25
2	Description	26
2.1	Product description	26
3	Use	27
3.1	Before first use	27
3.2	Assembly	27
3.3	Using the slow juicer	29
4	Cleaning and maintenance	33
4.1	Instructions	33
4.2	Cleaning the surfaces	33
4.3	Cleaning the slow juicer	33
4.4	Removing the seals and rotating brush for cleaning	33
4.5	What to do if...	35

We advise you to read this manual carefully, it contains all the instructions for maintaining the appliance's aesthetic and functional qualities.

For further information on the product: www.smeg.com

The manufacturer reserves the right to make any changes deemed useful for improvement of its products without prior notice. The illustrations and descriptions contained in this manual are therefore not binding and are merely indicative.



Instructions

1 Instructions

1.1 Introduction

Important information for the user:

Instructions



General information on this user manual, on safety and final disposal.

Description



Description of the appliance and its accessories.

Use



Information on the use of the appliance and its accessories, advice regarding preparations.

Cleaning and care



Information for correct cleaning and care of the appliance.



Safety instructions



Information



Advice

1.2 User Manual

This user manual is an integral part of the appliance and must therefore be kept in its entirety and in an accessible place for the whole working life of the appliance.

1.3 Intended use

- The appliance is designed exclusively for home use.
- Do not use the appliance for anything other than the intended use.
- Use the appliance indoors.
- The appliance can be used to extract fruit and vegetable juices for various preparations.
- The appliance is not designed to operate with external timers or with remote-control systems.
- This appliance must not be used by people (including children) of reduced physical, sensory or mental capacity, or lacking in experience in the use of electrical appliances, unless they are supervised or instructed by adults who are responsible for their safety.



1.4 General safety instructions

- Do not plug in or unplug with wet hands. This may cause electric shock or injury.
- Plug the power cord correctly and push it tight in a wall socket. This may cause electric shock or fire.
- If the supply cord is damaged, it must be replaced by the manufacturer, its service or similarly qualified persons in order to avoid a hazard. If the power cord is damaged, it may cause electric shock or fire.
- Never alter the appliance. Also, do not disassemble or repair by yourself. Do not insert fingers, foreign substances or objects such as pins into gaps or holes in the body. This may cause a fire, electric shock or failure. For any technical support, contact the authorised local Customer Care Centre.
- In case the power cord breaks or is damaged or the plug-in part becomes loose, do not operate it. This may cause electric shock, fire or injury.
- Do not moisten the body or splash water on the body. Be careful not to let any liquids or other substances get into the switch on the appliance. Do not operate the switch with wet hands. It may cause electric shock or fire.
- For your safety, have the grounding connection performed. Make sure that the grounding is not done on gas pipes, plastic water pipes, telephone wires, etc. This may cause electric shock, fire, malfunction or explosion. Be sure to use the electrical outlet with ground connection.
- Never disassemble the chamber set during operation or insert fingers, foreign objects such as forks, spoons, etc. into the hopper chute or juice outlet. This may cause injuries, accidents or failure.
- Do not operate without locking the hopper properly. It may cause injury or failure.
- When detecting a gas leak, do not insert the power cord into its slot. Open the window immediately to ventilate fully. This may cause injury or failure.
- Never put fingers, forks or spoons, etc. into the juice outlet. This may cause injury or failure.
- If rotation of the auger is stopped in normal operation, activate the **REVERSE** function and hold for 2-3 seconds and then after the **REVERSE** function has stopped completely, press the **ON** button again. If the auger keeps stopping during operation, the parts may get damaged and performance may be affected due to the motor overheating. If the problem persists, stop the appliance immediately and contact your local Customer Care Centre.



Instructions

- During operation, do not try to move the body, disassemble the chamber set or parts and try to lock them. This may cause injuries or failures. Always switch off the appliance and unplug the power cord before carrying out any operation.
- When using the appliance, avoid wearing neckties, long necklaces, scarves, etc., which could get entangled into the hopper chute. This may cause injury, failure or breakage.
- Place the appliance on a flat and stable surface. This may cause injury or failure.
- Do not operate the appliance for more than 30 minutes at a time. This may cause a motor failure due to overheating. Cool it down sufficiently for about 5 minutes and operate it again.
- When placing ingredients into the hopper chute, only use the pusher provided. This may cause injury or failure.
- Avoid dropping or causing a severe shock to the appliance. It may cause electric shock, fire or damage.
- If the appliance gives off an unpleasant smell or it heats excessively or smokes, stop using it immediately and contact your local customer care centre. When using a new appliance, it gives off a smell and this disappears naturally over time.
- Always unplug the appliance after use. Always disconnect the appliance from the supply if it is left unattended and before assembling, disassembling or cleaning. When unplugging the power cord, make sure to hold the power cord. Pulling on the wire to unplug may cause electric shock or fire.
- Do not wash at high temperatures of 80°C or higher. Do not put the appliance in a dishwasher, a dryer or a microwave, etc. This may cause a failure or parts deformation.
- The appliance weighs about 6.2kg. When moving the appliance, ensure to move it holding the grips tightly at the bottom of the body with both hands. If you try to hold the chamber or the edge of the body, the base is likely to fall and cause injury or failure.
- Appliances can be used by persons with reduced physical, sensory or mental capabilities or lack of experience and knowledge if they have been given supervision or instruction concerning use of the appliance in a safe way and if they understand the hazards involved. Children shall not play with the appliance. Cleaning and user maintenance shall not be performed by children. This appliance shall not be used by children. Keep the appliance and its cord out of reach of children.



1.5 Manufacturer liability

The manufacturer shall not be held responsible for personal injuries or property damage caused by:

- Any use of the appliance other than the one it was designed for.
- Not having read the user manual.
- Tampering with any part of the appliance.
- The use of non-original spare parts.
- Not following the safety instructions.

1.6 Identification plate

The identification plate bears the technical data, serial number and brand name of the appliance. Do not remove the identification plate for any reason.

1.7 Disposal



This appliance must be disposed of separately from other waste (Directive 2012/19/EU). The appliance does not contain substances in quantities sufficient to be considered hazardous to health and the environment, in accordance with current European directives.

- **Old electrical appliances must not be disposed of together with domestic waste!** To comply with current legislation, electrical appliances, on reaching the end of their useful lives, should be taken to an appropriate recycling centre for electrical and electronic waste. In this way, any valuable material contained in the old appliances can be recycled, helping to protect the environment. The relevant local authorities or their waste disposal operators can provide further information.

Our appliances are packed in non-polluting and recyclable materials.

- Dispose of the packing materials at an appropriate recycling facility.



Plastic packaging Danger of suffocation

- Do not leave the packaging or any part of it unattended.
- Do not let children play with the plastic bags.



Electrical voltage Danger of electrocution

- Disconnect the main power supply.
- Unplug the appliance.



Description

2 Description

2.1 Product description

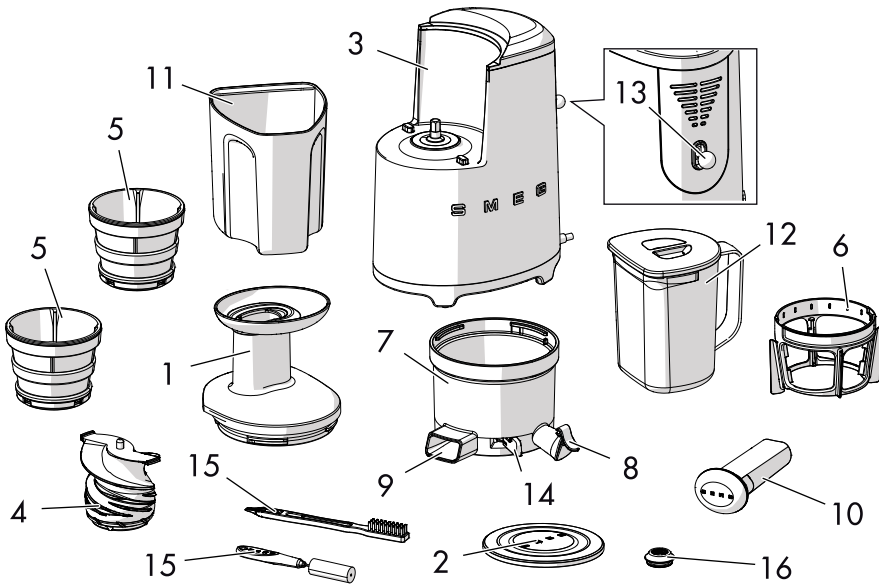

Slow juicer - model SJF01

- | | |
|-------------------------------|--|
| 1 Hopper | 11 Pulp container |
| 2 Hopper lid | 12 Juice jug with lid |
| 3 Motor body | 13 Lever switch/Reverse function lever |
| 4 Auger | 14 Juice density regulation lever |
| 5 Strainers (fine and coarse) | 15 Cleaning brushes |
| 6 Rotating brush | 16 Seal |
| 7 Juice collector bowl | |
| 8 Juice outlet | |
| 9 Pulp outlet | |
| 10 Pusher | |

i The utensils and accessories intended to come into contact with food are made of materials that comply with the provisions of current legislation.



3 Use



Danger of electrocution

- Plug the appliance into a grounded three-pin socket.
- Do not remove earth prong.
- Do not use an adapter.
- Do not use an extension cord.
- Failure to follow these instructions could result in death, fire, or electrical shock.

3.1 Before first use

1. Remove any protective packaging from the outside or inside of the appliance, and its accessories.
2. Remove any labels (apart from the technical data plate) from the appliance, its parts and components.
3. Clean the parts and components of the appliance (see "4 Cleaning and maintenance").
4. Clean the body of the appliance using a damp cloth.
5. Dry the components thoroughly and install them.

3.2 Assembly

1. Insert the strainer (1) into the slots on the rotating brush (2) until it locks into position.

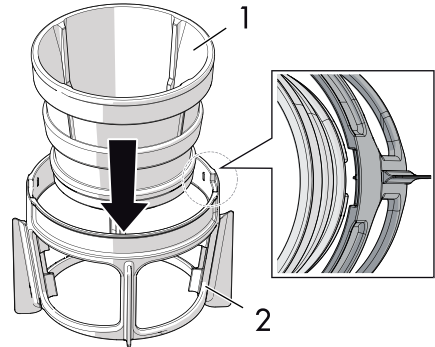

2. Check that the strainer (1) is correctly positioned inside the rotating brush (2).

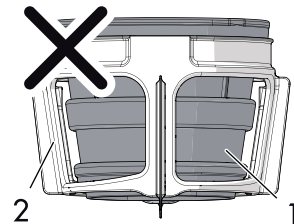
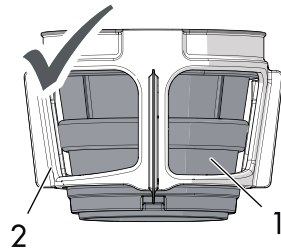



Description

3. Position the strainer unit (1) and rotating brush (2) inside the juice collector bowl (3) so as to insert the unit into the slots (4) on the bottom of the bowl.

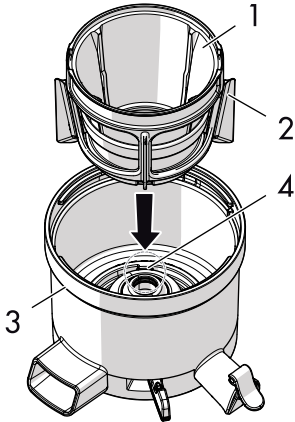

5. Place the hopper (7) onto the bowl, turning it clockwise until it locks into position.

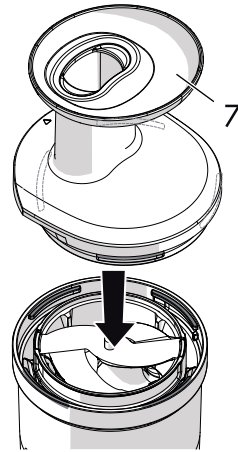

4. Position the auger (5) by turning it so that it fits into the slots (6) on the rotating brush (2).

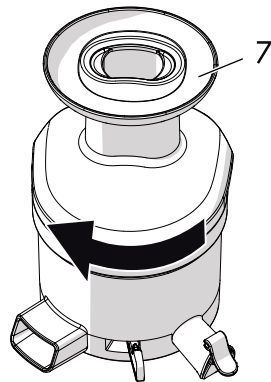
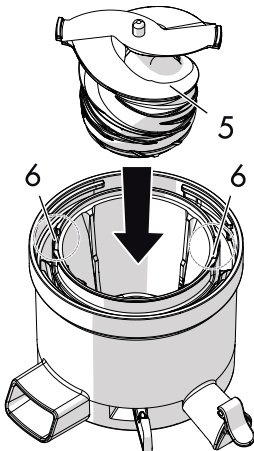



6. Install the assembled unit (8) onto the motor body (9). Make sure that the juice density regulation lever (10) is in the **CLOSE** position.

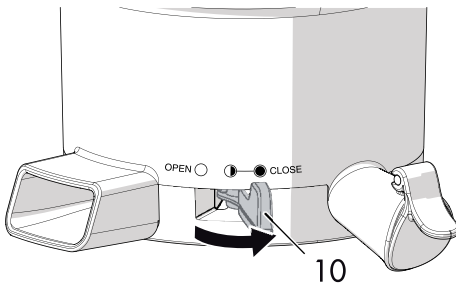
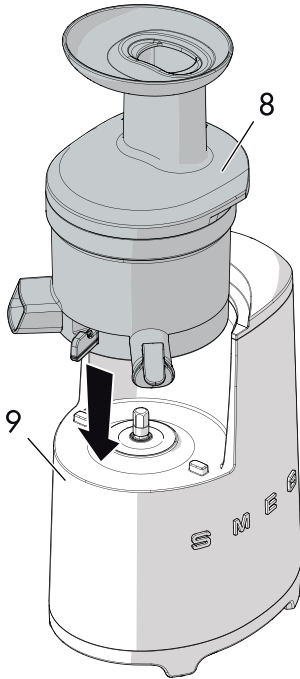

3.3 Using the slow juicer

1. Check that the juice density regulation lever (10) is in the **CLOSE** position before starting the appliance.

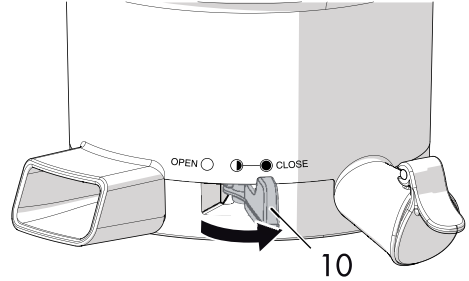

2. Place the juice jug (11) and the pulp container (12) under the relative outlets (13) and (14).

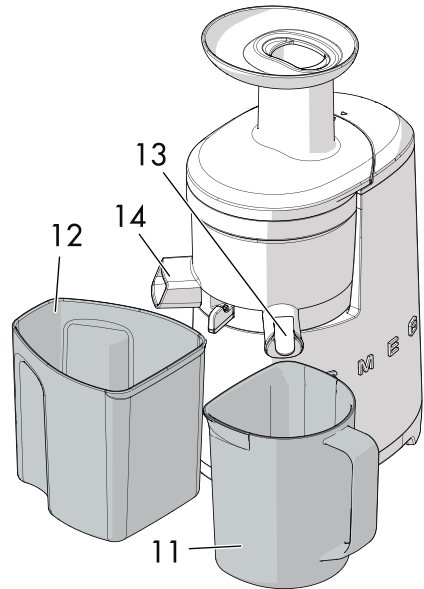



Use

3. Push the lever switch upwards (15) to start the juicer.

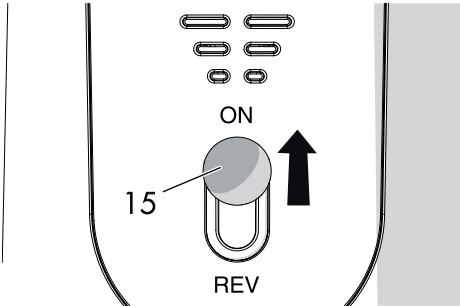

4. Introduce the ingredients into the feed chute of the hopper (16) a little at a time using the pusher provided (17).

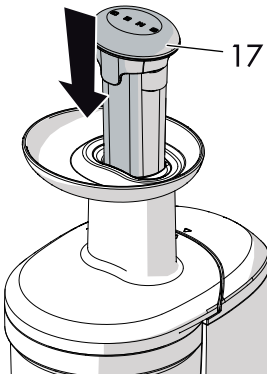
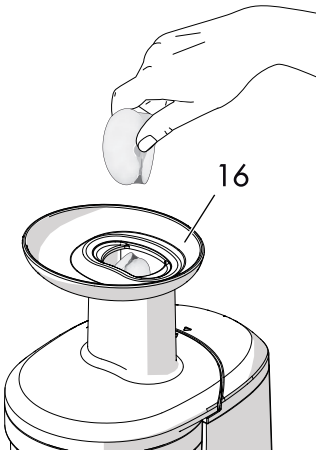

5. Open the juice outlet (18) before the juice collector bowl becomes full and move the juice density regulation lever (10) to the half-open position (◐) before adding the last ingredients.

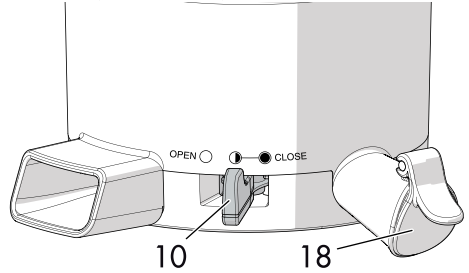

6. When juicing is complete, stop the juicer, placing the lever switch (15) to the middle position.

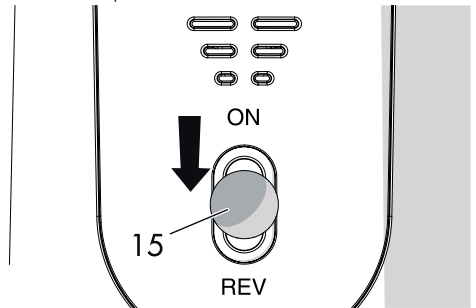



How to use the juice density regulation lever

CLOSE position

Use the lever in the **CLOSE** position during the initial phases of fruit or vegetable juice extraction.

HALF-OPEN position

Use the lever in the **HALF-OPEN** position during the last phases of juicing, when the final ingredients are introduced and when removing residues.

If semi-hard ingredients are used such as grapes, pomegranates, blackberries, etc. move the lever into this position as soon as the juice starts to exit from the outlet.

OPEN position



Use the lever in the **OPEN** position when cleaning the juice collector bowl.

Advice for using the juice density regulation lever

Ingredients:

Apples, pears, melon, strawberries, blueberries, plums, peaches, cherries, pineapple, orange, lemon, grapefruit.

Carrots, ginger, potatoes, beetroot, broccoli, cauliflowers, cucumbers, cabbage, savoy cabbages, spinach, walnuts, almonds.



1. Place the lever in the **CLOSE**  position before juicing.
2. When juicing is nearly complete, move the lever to the **HALF-OPEN**  position.



- Remove the seeds or stones from fruit such as persimmons, apricots, lemons, plums, peaches, etc. before juicing.
- Stalk vegetables with tough fibres such as celery, fennel, cardoons, etc. should be cut into pieces of approximately 3-4 cm.
- Do not introduce sesame seeds, coffee beans or peppercorns.
- Do not introduce fruit or vegetables preserved in alcohol, sugar, honey, etc. They could damage the appliance or cause it to malfunction.
- It is best to consume the juice from leafy green vegetables and fruit immediately after juicing for a better absorption of vitamins and nutrients.

Seed fruit:

Grapes, pomegranates, kiwi fruit, blackberries.

1. Place the lever in the **CLOSE**  position before juicing.
2. When the juice starts to come out, move the lever to the **HALF-OPEN**  position.

Ingredients to mix with milk:

Bananas, strawberries, blueberries, etc.

1. Move the lever to the **CLOSE**  position.



Use



Moving parts Risk of personal injury or damage to the appliance

- Do not operate the appliance for more than 30 minutes at a time. Leave the appliance to cool down and wait 5 minutes before starting it again.
- Do not insert fingers, forks or spoons into the juice and pulp outlets. This could cause personal injury or damage the appliance.
- Keep hands, hair, clothing, spatulas and other objects away from the feed chute of the hopper to avoid personal injury or damage to the appliance.
- Only use the pusher provided to push the ingredients into the feed chute of the hopper.

Advice on which strainer to use

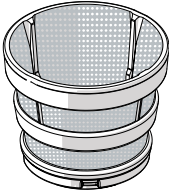
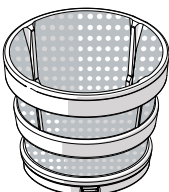
Strainer	Suitable for
<p>Fine</p> 	<p>Pure fruit or vegetable juices.</p>
<p>Coarse</p> 	<p>Dense juices containing pieces of pulp, smoothies, milk shakes or soups.</p>

How to use the REVERSE function

The **REVERSE** function is used when the auger stops during operation:

- Keep the lever switch pressed downwards for 3-5 seconds at a time. Repeat this process 2-3 times.



The **REVERSE** function pushes the ingredients upwards, releasing the auger and allowing the appliance to operate correctly.



If the auger continues to stop during operation, unplug the power cable, remove the juice collector bowl and clean it.



4 Cleaning and maintenance

4.1 Instructions



Improper use Danger of electrocution

- Switch off and unplug the appliance before cleaning it and its parts.



Improper use Risk of damage to surfaces

- Do not use steam jets to clean the appliance.
- Do not use cleaning products containing chlorine, ammonia or bleach on steel parts or parts with metallic finishes on the surface (e.g. anodizing, nickel- or chromium-plating).
- Do not use abrasive or corrosive detergents (e.g. powder products, stain removers and metallic sponges).
- Do not use rough or abrasive materials or sharp metal scrapers.

4.2 Cleaning the surfaces

To keep the surfaces in good condition, they should be cleaned regularly after use. Let them cool first.

4.3 Cleaning the slow juicer

1. Remove the hopper, auger, bowl, strainer and rotating brush assembly from the juicer body and disassemble it into its various parts.
2. Use the cleaning brushes provided to clean and wash the parts under running tap water.
3. Clean the body of the juicer using a damp cloth.
4. Dry parts thoroughly before reinstalling them.

4.4 Removing the seals and rotating brush for cleaning

- **Juice outlet seal:** Open the juice outlet cap and hold the juice collector bowl and outlet steady with one hand and remove the seal with the other.

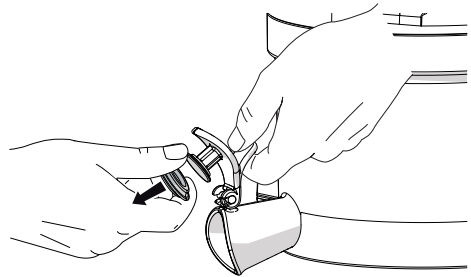



Cleaning and care

- **Juice collector bowl seal:** Grasp the seal on the bottom of the bowl and lift upwards to remove it.

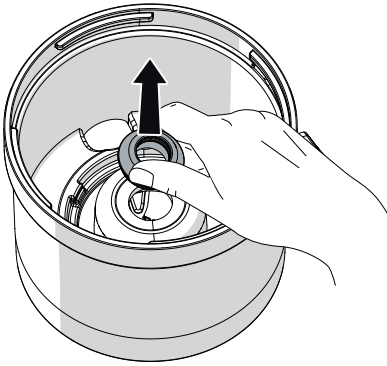

- **Rotating brush:** Remove the blades as shown.

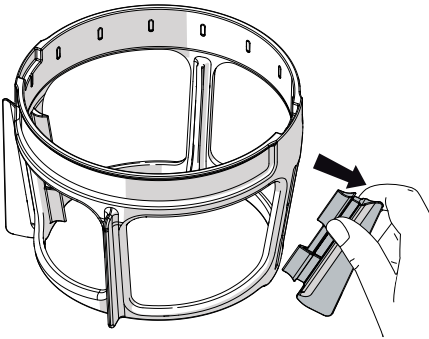

- Use the cleaning brush provided to clean the internal and external parts of the rotating brush unit under running tap water.

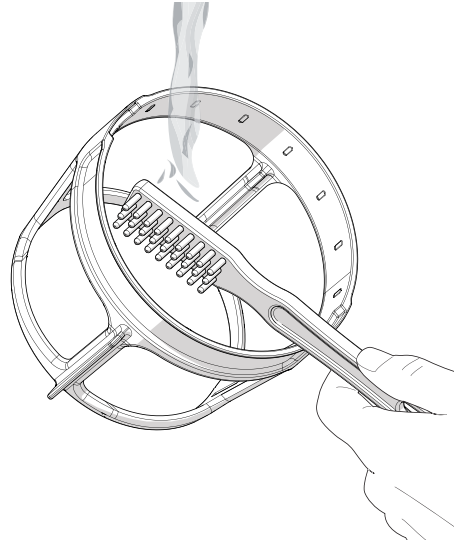

Clean and wash the slow juicer immediately after use. Residues may dry out and make disassembly and cleaning difficult, as well as affect the operation of the appliance.



4.5 What to do if...

Problem	Probable cause	Solution
The appliance does not work	The plug is not properly inserted into the power socket.	Insert the plug into the power socket. Do not use adaptors or extension cords. Check that the main power switch is turned on.
	The hopper has not been installed properly.	Make sure that the hopper is installed properly following the assembly instructions.
It is not possible to detach the hopper	Excessive residue	Place the lever into the half-open position and run the appliance in order to remove the residues. Activate the REVERSE function for 3-4 seconds at a time. Repeat 2-3 times.
	Presence of hard seeds.	In case of hard seeds, activate the REVERSE function in order to push the ingredients towards the feed chute of the hopper.
The auger stops during operation	The container is too full.	Use the REVERSE function. If the problem persists, contact an authorized service centre.
The juice drips onto the outside of the juicer body	Excessive quantity of ingredients in the hopper feed chute.	Remove some of the ingredients and introduce them gradually.



Cleaning and care

Problem	Probable cause	Solution
The juice collector bowl does not fit onto the juicer body	Lever is in the OPEN position.	Before fitting the bowl onto the juicer body make sure that the lever is in the CLOSE position.
The juice collector bowl vibrates when the juice is being extracted	Hard ingredients (carrots, chicory, beetroot, etc.)	A slight vibration is normal, especially when processing hard ingredients.



If the problem has not been resolved or in the case of other types of fault, contact your local technical support centre.